

DH98i

Industrial Door Motion & Presence Detector

INSTALLATION INSTRUCTIONS

Section 1

General Description

The DH98i is a microprocessor controlled active infrared motion and presence detector which serves two purposes. First, it is designed to activate any industrial automatic door made today. Second, it provides presence detection close to all types of industrial automatic doors.

- Wide and narrow pattern width of the sensor is adjustable by twin revolving lens units.
- Pattern depth and width are adjustable using mounting height, dip switches, pattern width and pattern angle adjustments.
- Frequency is selectable in four channels
- Self-Diagnostic means the sensor continuously monitors itself.
- Snow Mode Switch ensures against false operation caused by snow, insects, etc.
- Microprocessor provides programmable Presence Timer (2 sec., 60 sec., 10 min. or Infinite).



Section 2

Parts Identification

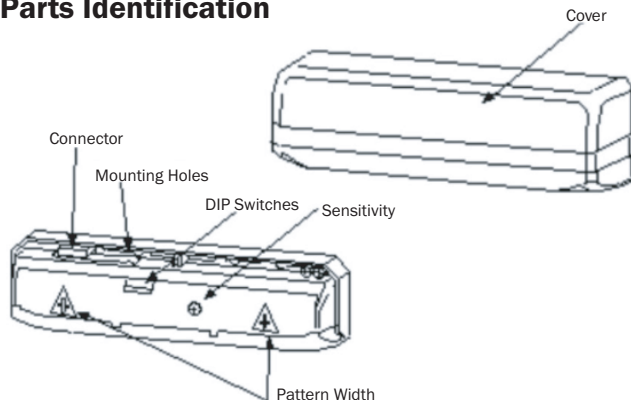

Accessories

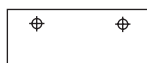

Mounting Template



Mounting Screws



Connection Cable
5 ft. (1.5m)



Instructions

Section 3

Mounting Information

1. Do not mount higher than 13 ft. (4m).
2. Do not leave any objects which may move in the detection pattern.
3. Do not mount where rain or snow will fall directly on unit.
4. Do not mount in a place where reflection of sunlight will shine on unit.
5. Do not mount in a humid or steamy environment.
6. Do not mount five devices in proximity to each other. When using from 2 to 4 devices in proximity, use alternate frequency settings as shown below. (Maximum 4 sensors)

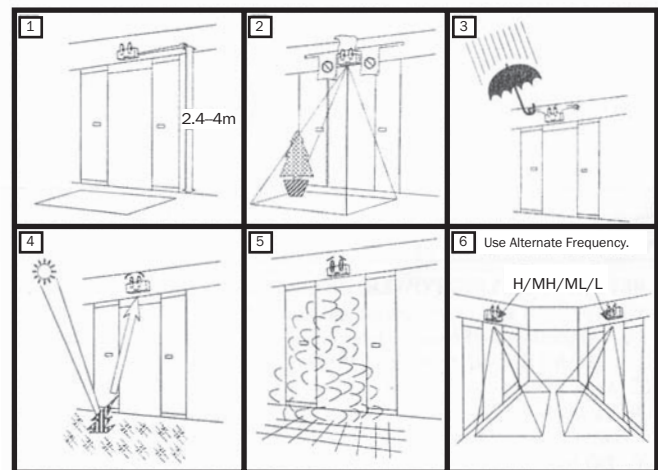

Section 4

Mounting and Wiring

1. Using the mounting template provided, drill mounting and wire holes.
2. Remove cover using a screwdriver.
3. Fasten unit with mounting screws provided.
4. Connect wiring. Push amp connectors tightly together.

Red & Black = Power [Nonpole]
Yellow = Normally Open [NO]
Green = Normally Closed [NC]
White = Common

DH98i

Industrial Door Motion & Presence Detector

INSTALLATION INSTRUCTIONS

Mounting and Wiring (continued)

- Set desired sensor parameters as noted in Sections 5 & 7.

⇒ **5. DIP Switch Settings**
 ⇒ **7. Adjusting Detection Pattern**

- Place cover on sensor and clean the sensor.

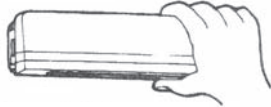

NOTE: For maximum pattern depth and width, mount the DH98i at 13 feet and use the maximum pattern angle (10°).



NOTE: The DH98i can be mounted using the optional DH97-BDB or DH97-MP mounting brackets when more flexible mounting is required (See Section 14).

Section 5

Dip Switch Settings

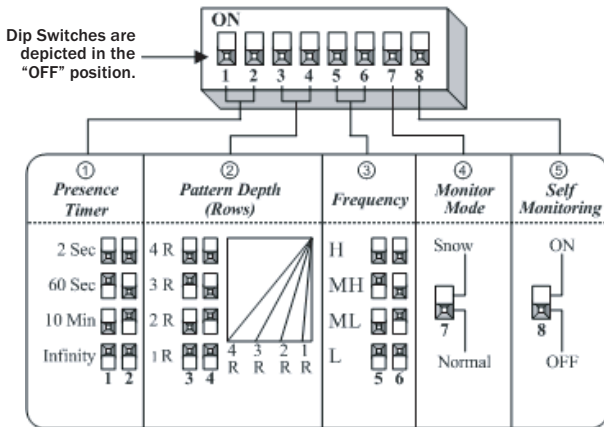

- Presence Timer:** Only rows 1 & 2 will detect a stationary object for the time period set by the Presence Timer. If selected, the DH98i will provide infinite presence detection for rows 1 & 2.
- Pattern Depth (Rows):** To adjust the pattern depth, set switches 3 & 4 as shown.
 Rows 1 & 2 = Presence Detection
 Rows 3 & 4 = Motion Detection
- Frequency:** When more than two sensors are used in close proximity to each other, to prevent interference use alternate frequency settings. (H + MH + ML + L = Maximum 4 sensors).

- Monitor Mode:** A Snow Mode is available. Snow Mode should only be used in environments with heavy snowfall or other extreme conditions.
- Self-Monitoring:** "ON"=When power is first supplied to the DH98i, the sensor automatically performs a Self Diagnosis (See Section 9).

Section 6

Power

BEFORE APPLYING POWER, READ AND FOLLOW THESE INSTRUCTIONS:

When power is applied, the sensor will read and store the environmental optical parameters. This is necessary for Presence Detection to work properly.

- CLEAR THE AREA OF ANY UNNECESSARY OBJECTS.
- Apply POWER.
- Vacate the Detection Pattern immediately. While the sensor sees ANY moving objects in its DETECTION PATTERN, it will not proceed to the following step.
- DO NOT enter DETECTION PATTERN for 10 seconds (Presence Detection Setting).
- TEST the presence feature, especially near the door.

When carrying out the following work, TURN OFF THE POWER:

- When the floor conditions change.
- Adjusting pattern or sensitivity.

Section 7

Adjusting Detection Pattern

Adjust the detection pattern according to the following diagrams:

- Pattern Angle Adjustment.

SIDE VIEW/DETECTION PATTERN

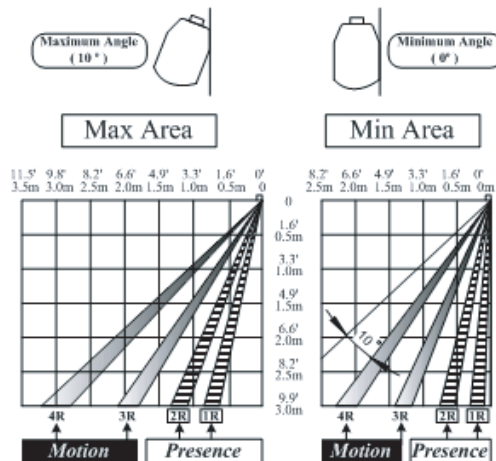

- The body of the sensor can be rotated from 0° to 10° (5 steps).

DH98i

Industrial Door Motion & Presence Detector

INSTALLATION INSTRUCTIONS

2. Pattern Width Adjustment.

Pattern Adjustments for single and/or double doors by Side Levers.

FRONTAL VIEW/DETECTION PATTERN

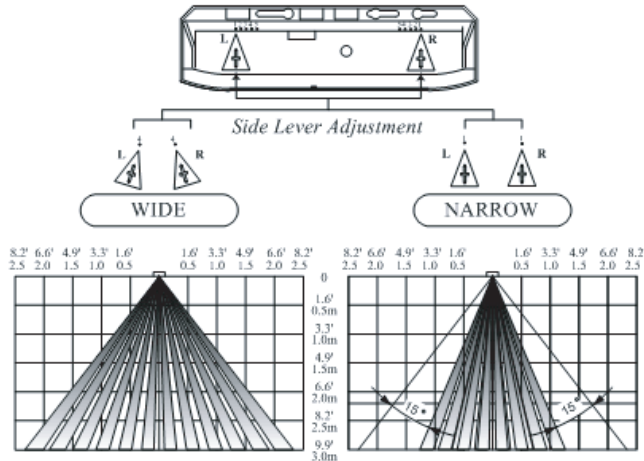

- The body of the sensor can be rotated from 0° to 10° (5 steps).



Detection pattern will vary according to objects, material, color and speed.

Section 8

Verification of Operation

- After mounting, setting parameters and applying power, walk test unit to verify detection pattern.
- If the door does not operate properly, recheck the dip switch settings and pattern adjustments.
- After rechecking, if there is still a problem, adjust the sensitivity.

- Adjust high (clockwise) to increase sensitivity.
- Adjust low (counter-clockwise) to decrease sensitivity.

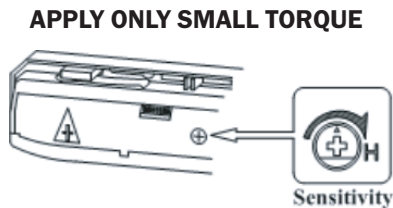

Section 9

Self Monitoring

Infrared beams are received on the receiver side of the DH98i, then the following occurs. For 12 seconds, the relay starts chattering ON/OFF (4 times in 12 seconds). Then the relay remains in the ON condition for 60

seconds. The cycle then repeats itself. At the same time, the Indicator LED will switch continuously between RED and GREEN. The door will remain in an Open position throughout.

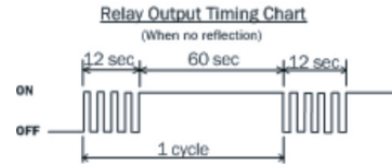

*****EXTREMELY IMPORTANT*****

After final set-up, test unit(s) completely to ensure that proper coverage has been achieved (width, depth and location of the pattern must be tested).

After the installation and operational check of the system:

- Place the proper labels on the door per all applicable standards.
- Instruct the owner of the door system operation and how to test it. This should be checked on a daily basis.
- Instruct the owner on what to do if the door or any of its components become damaged.
- Strongly recommend to the owner that the complete entry be inspected twice a year as part of the service agreement.

Section 10

Troubleshooting

PROBLEM 1: Door does not open

CAUSE 1: Sensor Connector

SOLUTION 1: Tighten connector or reconnect

CAUSE 2: Power Supply

SOLUTION 2: Check that the power supply is properly connected and 12V to 24V AC or DC

PROBLEM 2: Door operates intermittently

CAUSE 1: Sensor is very dusty or covered in water drops, etc.

SOLUTION 1: Clean the sensor (do not use thinner or alcohol to clean sensor)

CAUSE 2: Sensitivity too low

SOLUTION 2: Turn up sensitivity

CAUSE 3: Detection pattern in the wrong position

SOLUTION 3: Alter the detection pattern by changing sensor angle, dip switch settings and/or pattern width adjustments

DH98i

Industrial Door Motion & Presence Detector

INSTALLATION INSTRUCTIONS

PROBLEM 3: Door operates by itself

- CAUSE 1: Sensitivity too high
- SOLUTION 1: Turn down sensitivity
- CAUSE 2: Another sensor is too close by
- SOLUTION 2: Change the frequency to each sensor
- CAUSE 3: Sensor detects the door movement
- SOLUTION 3: If the indicator LED is an Orange color, adjust the pattern depth angle away from the door
- CAUSE 4: There is a cloth mat in the detection pattern
- SOLUTION 4: Turn the sensor power off and then on again, and allow it 10 seconds to reprogram
- CAUSE 5: Detection pattern too far in front of the door, detecting people passing by
- SOLUTION 5: Adjust the detection pattern - move it closer to the door
- CAUSE 6: The condition of the monitored area is varying (i.e., dusty, dirty, snow)
- SOLUTION 6: The condition of the detection zone can change due to heavy dust or dirty, heavy snow or footprints being left in fresh snow. This will cause the door to open sometimes. Set the Presence Timer to a short time. (See Section 7)

- Output Holding Time..... Approx. 0.5 seconds
- Presence Timer.....Limits of 2 sec., 60 sec., 10 min. and Infinity (Rows 1 & 2 only)
- LED Indication..... RED = Detecting
GREEN = Standby
ORANGE = Hunting Door
Switch between RED & GREEN = Abnormal
- Protection.....IP54 (IEC60529)
- Temperature Range..... -4 °F to 140 °F (-20 °C to 60 °C)
- Weight..... 0.77 lbs. (0.35kg)
- Color..... Black
- Accessories..... Cable: 5 ft. (1.5m)
Mounting Template
Installation Instructions

Section 11

Technical Data

- Model..... DH98i Motion & Presence Detector
- Detection Method.....Active Infrared Detection
- Max. Installed Height..... 13 ft. (4m)
- Pattern Adjustments..... Pattern Width (wide or narrow-side lever 1 to 4 position)
Pattern Depth (1 to 4 rows)
Angle Adjustment 0° to 10° in 5 steps, Sensitivity
- Detection Beams.....12 Beams*4 Rows=48 Beams
- Presence Detection..... 1 & 2 Rows (door side) by Presence Timer
- Motion Detection..... 3 & 4 Rows (approach side)
- Power Supply..... 12 to 24 V AC or DC ± 10%
- Power Consumption..... AC24V-3VA, AC12V-3VA
DC24V-75mA, DC12V-150mA
- Output Contact..... Form C Relay: DC50V 0.1A (Resistor Load)
Yellow Wire = Normally Open
Green Wire = Normally Closed
White Wire = Common

Section 12

External Dimensions

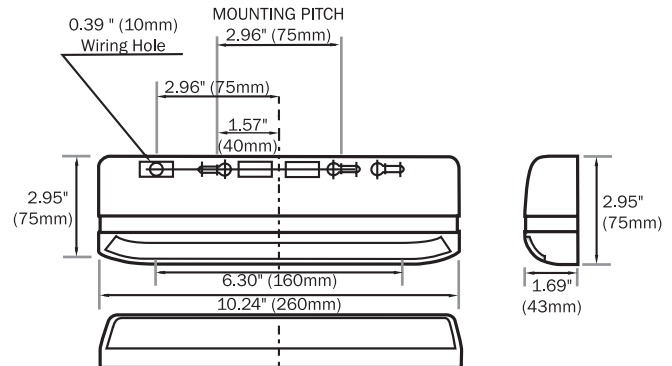

Section 13

Warranty

MS Sedco guarantees this product to be free from manufacturing defects for 3 years from date of installation. Unless MS Sedco is notified of the date of installation, the warranty will be in effect for 3 years from the date of shipment from our factory. If, during the first 3 years, our motion detector or support device fails to operate and has not been tampered with or abused, the unit can be returned prepaid to factory and it will be repaired free of charge. After 3 years, the unit will be repaired for a nominal service charge. **This limited warranty is in lieu of all other warranties expressed or implied, including any implied warranty of merchantability, and no representative or person is authorized to assume for MS Sedco any other liability in connection with the sale of our products. All warranties are limited to the duration of this written warranty. In no event shall MS Sedco be liable for any special, incidental, consequential or other damages arising from any claimed breach of warranty as to its products or services.**



DH98i

Section 14

DH97-BDB Backplate/Bracket and DH97-MP Mounting Plate

The DH97-BDB is an optional bracket for the DH98i sensor. It allows universal aim adjustment and adapts the DH98i for unique mounting requirements.

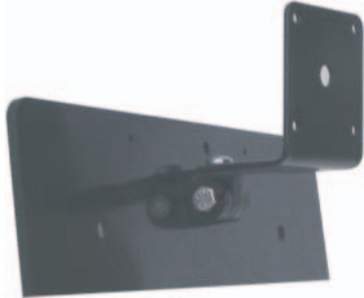

DH97-BDB

The DH97-MP is an optional mounting plate that adapts the DH98i sensor for mounting to a 1 3/4" door header. It can also be field prepped for a variety of unique mounting applications.

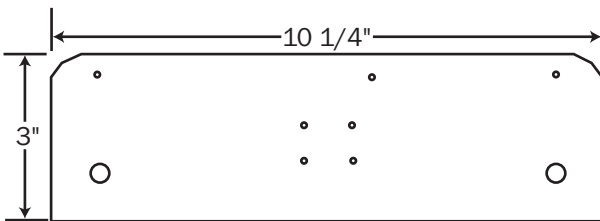

DH97-MP

(drawing not to scale)