

DH100

Sliding Pedestrian Door Motion & Presence Sensor

INSTALLATION INSTRUCTIONS

NOTE: Set up for this sensor should be performed by an AAADM-certified installer.

Section 1

General Description

The DH100 is a floor reflection method (FRM) active infrared combination motion and presence sensor that is designed to provide both activation and safety detection for automatic sliding and folding doors in a single device.

- Two outside rows provide motion detection only (activation).
- Three inside rows provide presence detection (safety).
- Pattern depth and angle are adjustable via dip switches and mechanical levers.
- Pattern width is adjustable via mechanical knobs.
- Frequency is selectable in four channels.
- Self-Diagnostic means the sensor continuously monitors itself.
- Snow mode switch ensures against false operation caused by snow, insects, etc.
- Both motion and presence timers are independently programmable.

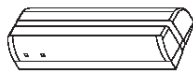

Section 2

Parts Identification

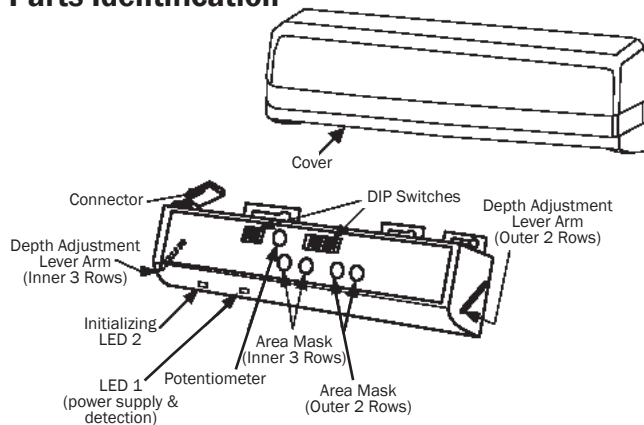

Accessories

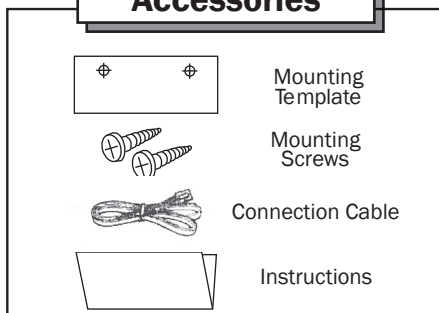

Section 3

Mounting Information

1. Do not mount higher than 9 ft. (2.7m).
2. Do not leave any objects which may move in the detection pattern.
3. Ensure rain or snow will not fall directly on unit.
4. Ensure snow or water can not accumulate on floor.
5. Ensure a minimum of reflected sunlight from the floor.
6. Avoid steamy environments.
7. Use different frequency settings for sensors in close proximity.
8. Use Infrared Safety Beams when required.

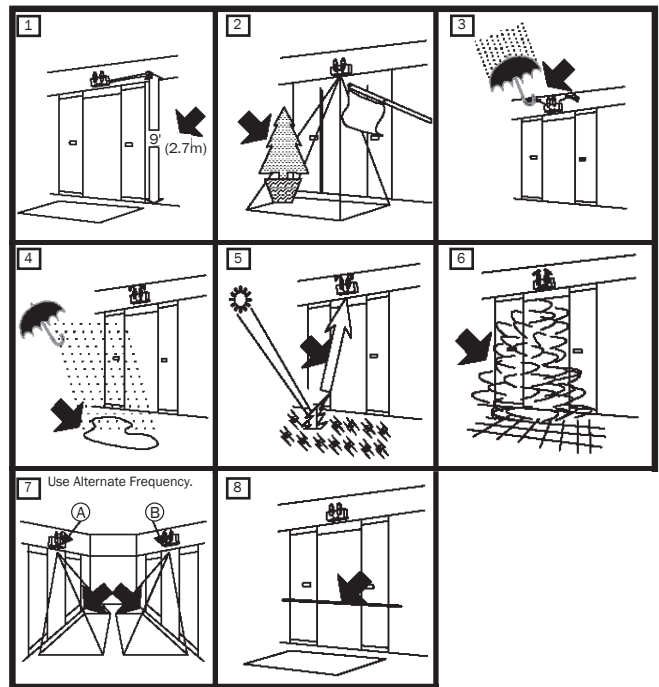

Section 4

Mounting and Wiring

1. Using the mounting template provided, drill mounting and wire holes.

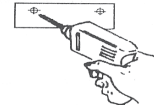

2. Remove cover using a screwdriver.

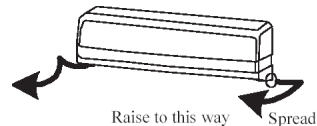

DH100

Sliding Pedestrian Door Motion & Presence Sensor

INSTALLATION INSTRUCTIONS

Mounting and Wiring (continued)

3. Fasten unit with mounting screws provided.

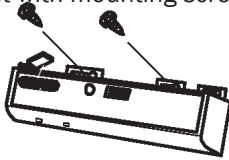

4. Connect wiring. Push amp connectors tightly together.

Red & Black = Power [Nonpole]
 Yellow = Normally Open [NO]
 Green = Normally Closed [NC]
 White = Common

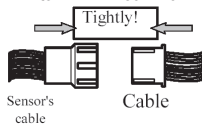

5. Set DIP Switch, Lever Arms, Potentiometer & Width Mask Knobs. See Sections 5 & 7.



⇒ 5. DIP Switch Settings
 ⇒ 7. Adjusting Detection Pattern

6. House connector in receptacle.

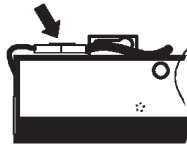

7. Replace cover.

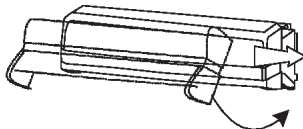

NOTE: For maximum pattern depth and width, mount the DH100 at 9 feet and use the maximum pattern angle (10°).

Relay Wire Information:

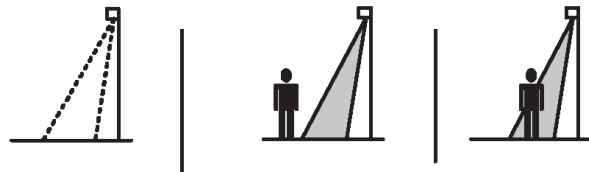

Yellow
 White
 Green

POWER
 FAILURE

Yellow (NO)
 White (COM)
 Green (NC)

NON-
 DETECTION

Yellow
 White
 Green

DETECTION

Section 5

Dip Switch Settings

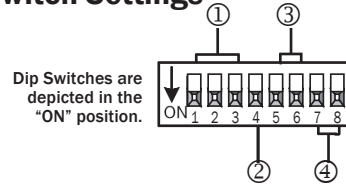

① **Presence Timer:** The sensor will detect a stationary object for the preset Presence Timer Setting. If the object does not move within the preset time period, then the door will close.

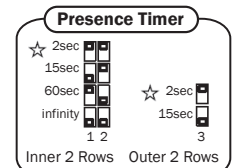

② **Monitor Mode:** Snow mode should only be used in exterior environments where heavy snow or other extreme conditions exist.

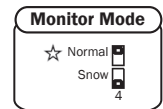

③ **Number of Rows:** The number of active rows can be set to 5, 4, 3 or 2.

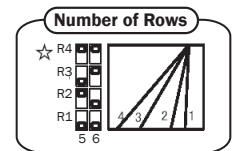

④ **Frequency:** When more than two sensors are used in close proximity to each other select different frequency settings for each sensor to prevent interference.

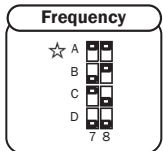

☆: Default Setting

Section 6

Power

BEFORE APPLYING POWER, READ AND FOLLOW THESE INSTRUCTIONS:

When power is applied, the sensor will read and store the environmental optical parameters. This is necessary for Presence Detection to work properly.

1. CLEAR THE AREA OF ANY UNNECESSARY OBJECTS.
2. Apply POWER.
3. Vacate the Detection Pattern immediately. While the sensor sees ANY moving objects in its DETECTION PATTERN, it will not proceed to the following step.
4. DO NOT enter DETECTION PATTERN for 10 seconds (Presence Detection Setting).
5. TEST the presence feature, especially near the door.

When carrying out the following work, TURN OFF THE POWER:

1. When the floor conditions change.
2. Adjusting pattern or sensitivity.

DH100

Sliding Pedestrian Door Motion & Presence Sensor

INSTALLATION INSTRUCTIONS

Section 7

Adjusting Detection Pattern

There are three ways to adjust the detection pattern. Make adjustments according to the following diagrams:

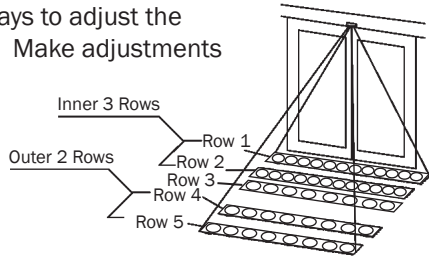

1. Depth Adjustment Lever Arm

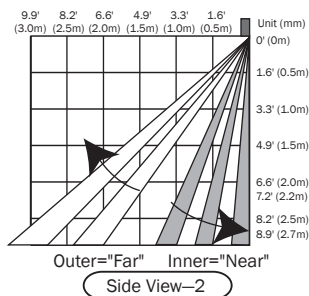
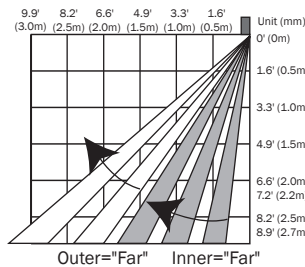
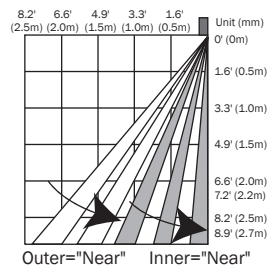
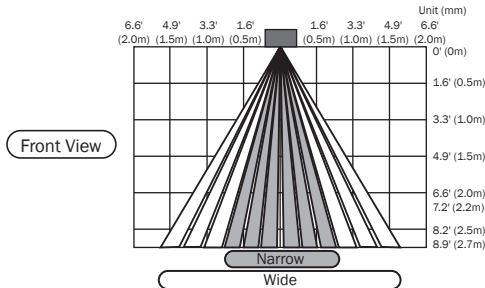
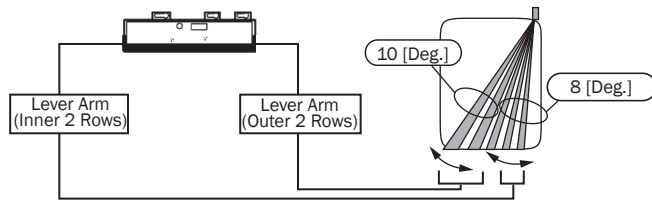

Optical beams are designed as shown above. Please note that actual detection area is variable, depending on cloths, materials on the floor and sensitivity adjustment. Please confirm the actual area after adjustment. Please refer to "Example of Effective Detection area."

2. Dip Switch

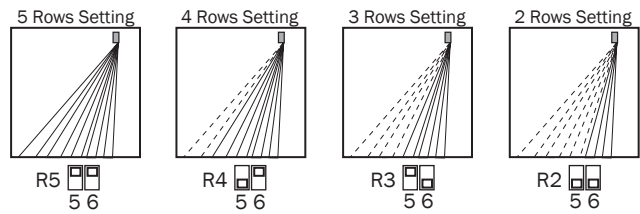

3. Sensitivity Potentiometer

APPLY ONLY SMALL TORQUE

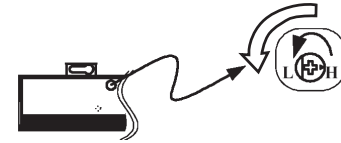

4. Width Mask Knobs

Width Mask Knobs (Inner 3 Rows) Width Mask Knobs (Outer 2 Rows)

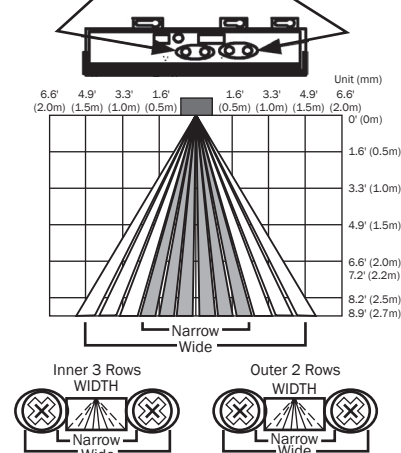

Example of Effective Detection Area:

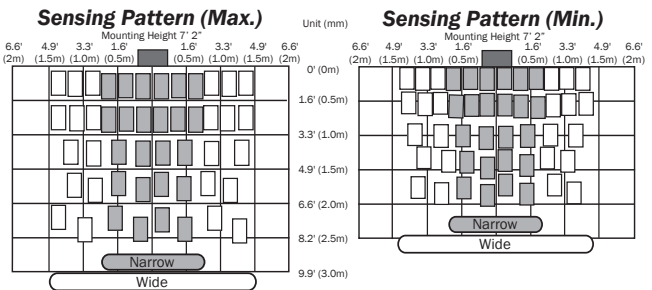

Under the following conditions:

Installation Height = 7.2' (2.2m)

Rows Available = "5"

Sensitivity Knob = "H" (Max.)

Lever Arm (Outer) = "Far"

Lever Arm (Inner) = "Far"

Always note that actual detecting area will be varied depending on material of floor and clothes.

Section 8

Verification of Operation

1. After mounting, setting parameters and applying power, walk test unit to verify detection pattern.
2. If the sensor does not function as expected, TURN OFF THE POWER and RECHECK the Depth Adjustment Lever Arms, Dip Switch and Width Mask Knobs as described in Sections 5 and 7.
3. After rechecking, if there is still a problem, adjust the sensitivity.

*******EXTREMELY IMPORTANT*******

After final set-up, test unit(s) completely to ensure that proper coverage has been achieved (width, depth and location of the pattern must be tested).

After the installation and operational check of the system:

1. Place the proper labels on the door per all applicable standards.
2. Instruct the owner of the door system operation and how to test it. This should be checked on a daily basis.
3. Instruct the owner on what to do if the door or any of its components become damaged.
4. Strongly recommend to the owner that the complete entry be inspected twice a year as part of the service agreement.

Section 9

Troubleshooting

PROBLEM 1: Door does not operate

- CAUSE 1: Sensor Connector.
SOLUTION 1: Tighten connector or reconnect.
- CAUSE 2: Power Supply.
SOLUTION 2: Check that the power supply is properly connected and 12V to 24V AC or DC.

PROBLEM 2: Door operates intermittently.

- CAUSE 1: Sensor is very dusty or covered in water drops, etc.
SOLUTION 1: Clean the sensor (do not use thinner or alcohol to clean sensor).
- CAUSE 2: Detection pattern is incorrect.
SOLUTION 2: Set the proper detecting rows using DIP Switch, Depth Adjustment Lever Arms and Width Mask Knobs.

PROBLEM 3: Door opens & closes halfway repeatedly (by hunting door movement).

- CAUSE 1: Detection row "ROW 1" is focused too close to the door.
SOLUTION 1: Set the Lever Arm of inner 3 rows away from the door. Or turn down the sensitivity with sensitivity adjustment knob.
- CAUSE 2: Detection pattern is incorrect
SOLUTION 2: Set the proper detecting rows using DIP Switch and Depth Adjustment Lever Arms

PROBLEM 4: Door operates by itself.

- CAUSE 1: Moving objects in detection area.
SOLUTION 1: Remove the moving object from the detection area.
- CAUSE 2: Outer 2 Rows are set too far from the door.
SOLUTION 2: Set the Lever Arm for the outer 2 rows closer to the door. Or reduce the detection rows by Dip Switch so as not to detect passing people.
- CAUSE 3: Sensitivity too high.
SOLUTION 3: Turn down the sensitivity with Sensitivity Potentiometer.
- CAUSE 4: Another sensor is installed nearby.
SOLUTION 4: Ensure different frequency setting for each sensor.
- CAUSE 5: The condition of monitored area changes suddenly. i.e. Dusty/Dirty/Snow, mat laid etc.
SOLUTION 5: The condition of the monitored area can change due to heavy dust or dirt, heavy snow or footprints being left in fresh snow. This may cause the door to remain open. Set the "Presence Timer" to a shorter time.

DH100

Sliding Pedestrian Door Motion & Presence Sensor

INSTALLATION INSTRUCTIONS

Section 10

Technical Data

Model.....	DH100 Combination Motion & Presence Sensor
Detection Method.....	Floor Reflection Method (FRM) Active Infrared
Max. Installed Height.....	9 ft. (2.7m)
Pattern Adjustments.....	Pattern Depth (2 to 5 rows via dip switch setting) and Angle Adjustment Levers (Outer 2 Rows 10° in 3 steps; Inner 3 Rows 8° in 3 steps) Pattern Width via 2 Position Mechanical Mask Knobs (Outer 2 Rows = Narrow or Wide Inner 3 Rows = Single or Double Door) Sensitivity via potentiometer
Detection Beams.....	UP TO 48 BEAMS Inner 2 Rows: 12 Beams x 2 Rows Outer Rows: 8 Beams x 3 Rows
Presence Detection.....	1, 2 & 3 Inner Rows (safety) timer selectable 2, 15, 60 sec. and infinity
Motion Detection.....	4 & 5 Outer rows (Approach) timer selectable 2, 15 sec.
Power Supply.....	12 to 24 V AC or DC ± 10%
Power Consumption.....	AC12V-1.5VA (Max.) DC12V-80mA (Max.) AC24V-2.0VA (Max.) DC24V-50mA (Max.)
Output Contact.....	Form C Relay: DC50V 0.1A (Resistor Load) Yellow Wire = Normally Open Green Wire = Normally Closed White Wire = Common Relay is "driven" when power fails
Output Holding Time.....	Approx. 0.5 seconds
Presence Timer.....	Outer 2 Rows (2, 15 sec.) Inner 3 Rows (2, 15, 60 sec. & infinity)
LED Indication.....	RED = Detecting GREEN = Standby ORANGE = Detection Row 1 is too close to the door
Temperature Range.....	-4 °F to 140 °F (-20 °C to 60 °C)
Weight.....	0.55 lbs. (0.25kg)
Color.....	Black
Accessories.....	Cable, Mounting Screws, Mounting Template, Installation Instructions

Section 11

External Dimensions

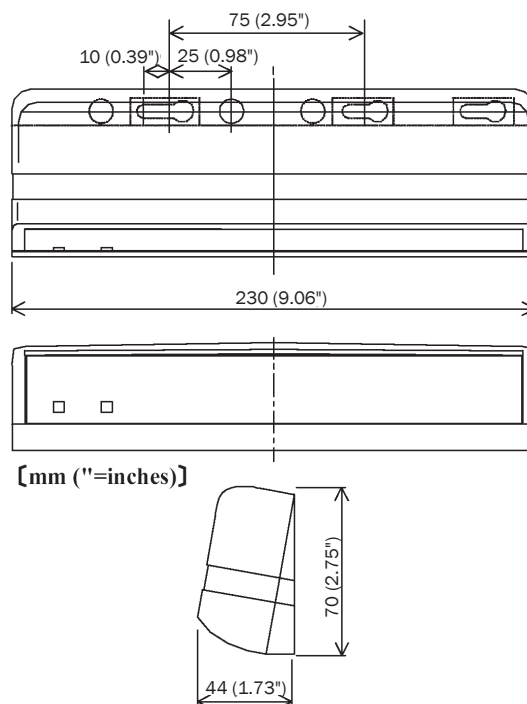

Section 12

Warranty

MS SEDCO guarantees this product to be free from manufacturing defects for 3 years from date of installation. Unless MS SEDCO is notified of the date of installation, the warranty will be in effect for 3 years from the date of shipment from our factory. If, during the first 3 years, our motion detector or support device fails to operate and has not been tampered with our abused, the unit can be returned prepaid to factory and it will be repaired free of charge. After 3 years, the unit will be repaired for a nominal service charge. **This limited warranty is in lieu of all other warranties expressed or implied, including any implied warranty of merchantability, and no representative or person is authorized to assume for MS SEDCO any other liability in connection with the sale of our products. All warranties are limited to the duration of this written warranty. In no event shall MS SEDCO be liable for any special, incidental, consequential or other damages arising from any claimed breach of warranty as to its products or services.**