



ENGINEERED FOR MOTION



TABLE OF CONTENTS

SECTION	DESCRIPTION	PAGE
1	Glossary	2-4
2	General Description	5
3	Installation	5-16
4	Adjustments	17
5	Changing the INTERSECTOR IP Address	18-26
6	Theory of Operation	27
7	Maintenance	28-29
8	Parts List	30
9	Electrical Interconnection Details & Drawings	30
10	Schematics	30
11	Assembly Drawings	30
Appendix A	Simulation Mode	A-1, A-2
Appendix B	TCIB Connections	B
Appendix C	Windows 7 Set-Up	C

GLOSSARY

MAIN SCREEN: The main screen is the first screen that will be displayed when the Intersector is connected to the Setup Port of the Interface board and a laptop is also connected to the Laptop Ethernet Port. From the Main Screen you will have two options:

1. **SETUP**
2. **ZONE SETTING**

SETUP: This page will give the installer five options:

1. **SIMULATION MODE ON:** This turns on simulation mode and will allow the installer to set the number of vehicles that will be displayed in simulation mode.
2. **SIMULATION MODE OFF:** Turns off simulation mode so you can monitor live traffic again.
3. **SET DEFAULT VALUES:** This will allow the installer to reset the sensor to factory settings.
4. **SETUP VEHICLE MAX PRESENCE TIME:** This will allow the installer to set how long the sensor will hold the presence of a vehicle that is within a detection zone, when the vehicle is stopped.
5. **SET RF CHANNEL:** This controls the frequency that the INTERSECTOR sensor will use for operation. For best results, use different channels for each sensor used at an intersection.

ZONE SETTING: This is the main entry to the programming screen for the INTERSECTOR. Units of either Meters or Feet can be selected from a drop down menu box called Unit Select on the Zone Setting Screen.

PROGRAMMING SCREEN (METERS OR FEET): This is the area where the installer can setup detection zones, Offset Angle, and track vehicle progress. This screen consists of three main parts: The Target Setup Table, Vehicle Table, and Data Display.

SET ZONE DATA: This function stores zone data to hard memory. When any data is changed on the Programming Screen, it will only be stored when this is selected.

TARGET SETUP TABLE: This section of the Programming Screen is where all setup data will be entered to be installed to the INTERSECTOR. The Table consists of several data values:

- **ZONE:** Zone is the term used to describe the area where the vehicle will be detected. In some cases this is known as the “loop”. Up to 8 separate zones can be created.
- **X:** X is the first coordinate used to determine the location of a zone. The X coordinate is the horizontal dimension and represents the distance from the sensor to the center of the zone in the X axis (Diagram 1).
- **Y:** Y is the second coordinate used to determine the location of a zone. The Y coordinate is the vertical dimension and represents the distance from the sensor to the center of the stop bar zone (Diagram 1).
- **Y Front:** This value extends the zone in front of the original point (closer to the intersection).

GLOSSARY

- **Y Behind:** This value is the depth of the zone behind the original point (farther from the intersection).
- **Width of Zone:** This is the width of the zone in relation to its center.
- **DELAY TIME:** Time that the detector will wait before allowing the output to be recognized.
- **EXTENSION TIME:** Time that the output will extend after a vehicle leaves the zone.
- **OPTO OUTPUT:** This value indicates the output for the controller input (rack). A setting of 0 indicates the output for this zone is currently disabled.
- **VEHICLE COUNT:** This is the total count of all vehicles that have entered this zone.
- **BIKE ONLY:** Selecting “bike only” will ignore larger vehicles and send a signal if a bike is present in the zone and moving at a speed of 18 mph (29 kph) or slower for those who want to provide additional time when bicycles are present.
- **ZONE DESCRIPTION:** User defined description of the zone that has been set up.
- **BREAD CRUMBS:** This feature simplifies zone alignment by displaying the path that each detected vehicle has traveled, illustrating lanes of traffic flow.
- **DAYS, HOURS, MINUTES, AND SECONDS:** This indicates the service time of the sensor.
- **SET SENSOR ORIENTATION:** This is the section where the X and Y coordinates are entered to calculate the Offset Angle that will allow electronic alignment of the sensor to the center of the desired detection area. Installers may enter the X and Y coordinates, or the Offset Angle. If the X and Y coordinates are entered, the Offset Angle will be automatically calculated. The Offset Angle can then be modified if necessary.
 1. X is the distance left or right of the sensor to the center of the desired detection area (left will be a negative number, right will be positive).
 2. Y is the distance from the sensor to the center of the stop bar zone.
 3. Offset Angle is typically between -12° to +12°.

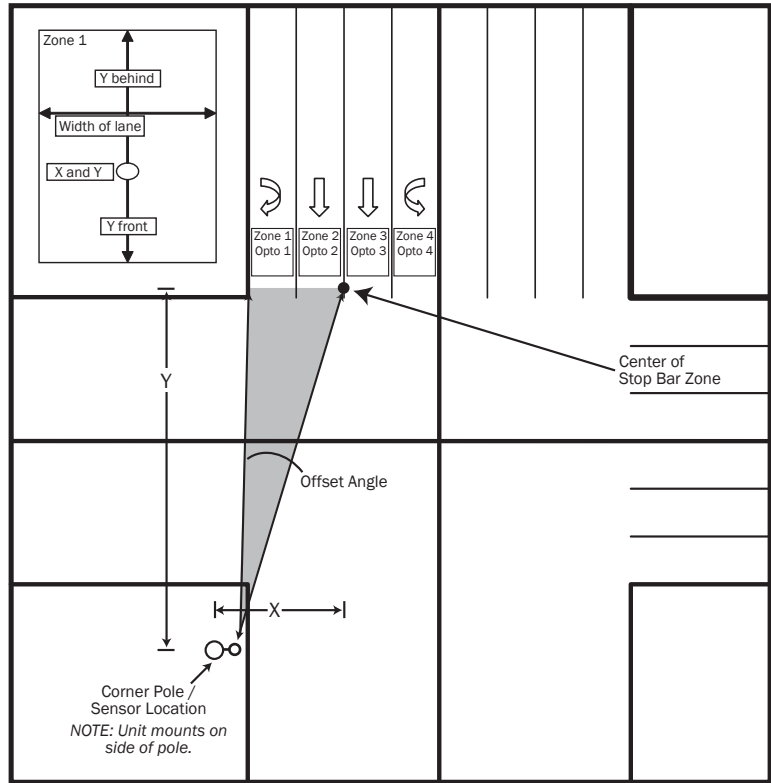

GLOSSARY

TABLE SETUP SECTION: This section consists of features useful in setting up the Target Setup Table.

ZONE SELECT: This value selects the zone to be programmed.

ID: This value selects the identification of a vehicle in the Vehicle Table which can be found directly below this setting. This value is used to copy the data of the selected vehicle.

COPY DATA: Selecting this feature will enter the information for the selected ID to the corresponding zone selected in Zone Select, in the Target Setup Table.

CLEAR VEHICLE COUNT: Resets the vehicle count for all zones.

SET EXCLUSION CIRCLE: Setting an exclusion circle improves sensor efficiency in heavy cross-traffic applications by ignoring vehicles that are first “seen” within the exclusion circle’s radius from the sensor. Typically, vehicles that first appear in this circle are cross-traffic, and data processing of oncoming traffic is improved by maintaining a focus on these vehicles. If used, the exclusion circle is typically set to 6’ (2 meters) less than the distance to the stop bar.

SET DISPLAY AREA: Repositions the Data Display area based on the following settings:

- **MOVE LEFT OR RIGHT:** Moves the Data Display area left or right based on the value entered. A negative value moves left, a positive value moves right.

STOP/START: This feature is used to Stop or Start the display of live data. The main use is to stop the display of data when a vehicle is present at a desired location. The data for this vehicle can then be copied into the Target Setup Table using Copy Data, to establish a zone.

OPTO OUTPUT: This is a visual indication of the sensor outputs that correspond to the interface board LEDs.

VEHICLE TABLE: This is a real time data table for the vehicle activity shown on the Data Display. This information can be used for setting up zones or tracking intersection activity. When the Stop button is selected, the data displayed will pause, and can be copied to the Target Setup Table. The actual data will continue to be gathered, even when the displayed data is paused. When the live display is restarted, the data will update to show the current values.

ID: The ID number is assigned to a vehicle (Vehicle Number) to aid in copying the data to the Target Setup Table.

VEHICLE NUMBER: This is the vehicle number that appears in the Data Display area of the screen.

X POSITION: This is the X position of the corresponding vehicle as it relates to the sensor.

Y POSITION: This is the Y position of the corresponding vehicle as it relates to the sensor.

SPEED: This is the speed for the corresponding vehicle.

DATA DISPLAY: This is the area that graphically displays the vehicle activity detected by the sensor.

GENERAL DESCRIPTION

The INTERSECTOR is a microwave vehicle motion and presence tracking sensor designed for intersection control. The INTERSECTOR offers several advantages when compared to cameras or loop detectors:



- Detection is not affected by weather
- Immune to sunrise/sunset or post-rain glare
- Not susceptible to in-road breakage
- Multiple lanes can be covered by a single unit
- Easily installs overhead to corner signal poles (Traffic lane closure may not be required)
- No privacy concerns
- Reduces construction costs (no special poles/bucket trucks required)

Through its user interface, the INTERSECTOR allows users to visually track vehicles as they approach the intersection and allows easy setup of detection zones to provide programmable inputs to a traffic control cabinet. The interface also provides the ability to verify that the system is functioning properly, or to troubleshoot the system, using a simulation mode.

INSTALLATION

INSTALLATION PREPARATION



NOTE: Remember to read all installation instructions carefully prior to installation of the unit. For a quicker installation, carefully pre-screen installation location. Prior to installation of the Intersector, please complete the INTERSECTOR worksheet. The worksheet is included with this manual.

Please inspect mounting location to ensure the following criteria are met:

- Mounting height should be between 14 feet and 19 feet.
- Distance from the sensor to the stop bar should not exceed 140 feet.
- Distance from the sensor to the closest detection zone should be at least 50 feet.
- Typical range of the TC-CK1-SBE is 400 feet.
- The TC-CK1-SBE has a detection width of 25 degrees. For best results the sensor should be mounted at a tip angle between horizontal to 3 degrees downward plus or minus the road slope.
- Installation requires a laptop with Internet Explorer version 6.0 or greater and at least 2 GB of RAM available.

INSTALLATION (continued)

TOOL REQUIREMENTS:

To properly install the INTERSECTOR, it is necessary to have the following tools on hand:

- Angle Meter
- 7/16" Box Wrench or Socket
- #2 Phillips Screwdriver
- Ethernet Cable Tester
- Modular Plug Termination Tool (Crimp Tool)

The INTERSECTOR is designed to be mounted at a height of 14 to 19 feet on a corner signal pole. Mount the sensor to the pole using stainless steel banding or bolts (not included). Make sure the sensor is mounted level.

INTERSECTOR ANGLE SETTINGS:

There are two angle settings for the INTERSECTOR; side to side (azimuth) and up and down (elevation). The azimuth setting is accomplished visually using the gun sight at the top of the unit. Aim the gun sight across the center of the stop bar region. Check to ensure that cars should be tracked approximately 20 feet past the stop bar for a left turn lane. To set the elevation, use a magnetic angle meter which is included in the Intersector installation kit. The table below suggests initial settings based on the distance from the unit to the stop bar. These settings may need additional adjustment depending on factors such as the slope of the road. Rotating the unit downward will decrease total range, but will ensure detection closer to the unit.

Stop Bar Distance Elevation Angle Typical Detection Distance
80 feet.....	-4 degrees	300 feet
100 feet.....	-2 degrees	400 feet
120 feet.....	-2 degrees	400 feet
140 feet.....	0 degrees (level).....	425 feet

Connection of the sensor to the traffic cabinet is accomplished using an Ethernet cable. The cable is routed through a quick connect assembly that is then connected to the sensor. The other end of the cable is routed to the traffic cabinet and plugs into the interface board. The next section will detail the preparation and installation of the sensor Ethernet cable.

INSTALLATION (continued)

QUICK CONNECT ASSEMBLY INSTRUCTIONS:

The quick connect consists of a shielded Cat. 5e RJ45 Plug, a load bar, and a Plug Housing Assembly.

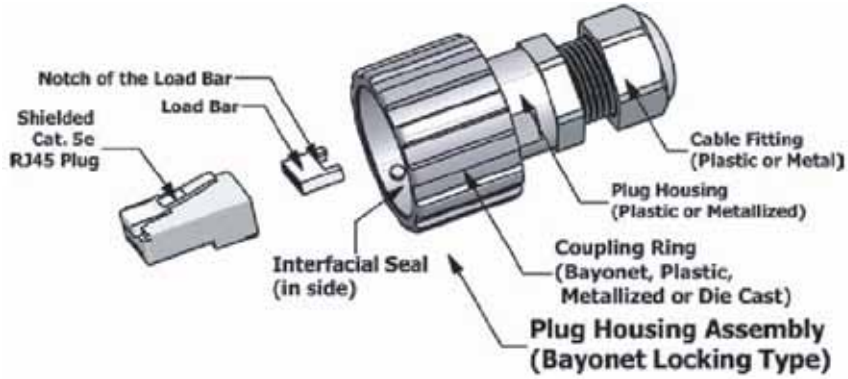

It is necessary to prepare the cable and insert it through the housing prior to attaching the load bar and Ethernet connector (RJ45 plug).



NOTE: Use only Cat.5e direct burial shielded cable.

INSTALLATION (continued)

CABLE PREPARATION: Using an 8 conductor, 24 AWG per conductor solid or stranded cable, the cable jacket should be stripped as shown in Figure 1 and then inserted through the cable fitting and the plug housing assembly.

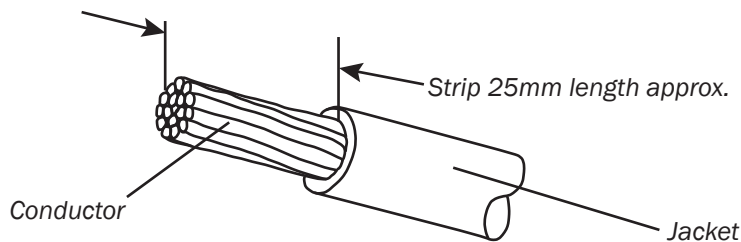

Figure 1

Conductors should be untwisted and aligned side by side for a T568B connector. Refer to Figure 2 to determine the proper alignment of the cable conductors.

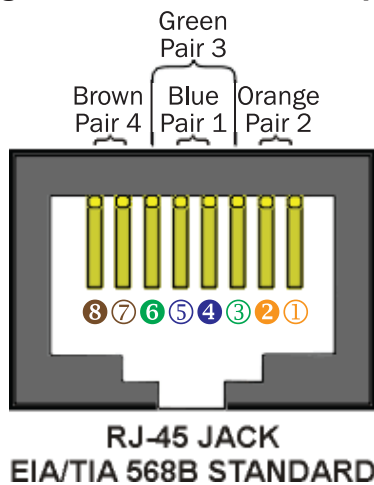

Figure 2

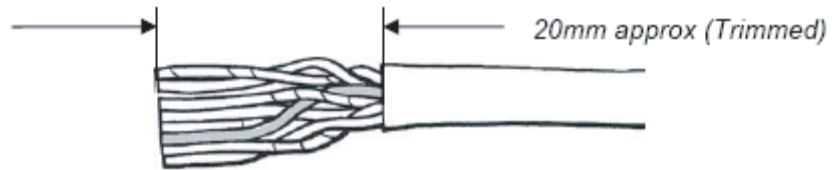

Figure 3

The conductor wire ends should be trimmed as shown in Figure 3. Untwist as little of the cable as possible. Be careful not to remove the insulation of individual conductors!

After inserting the wires into the appropriate positions of the load bar, slide the cable to a point where the cable jacket hits the notch of the load bar. Trim the remaining wire ends to approximately 5mm length as shown in Figure 4. Retract the cable, leaving approximately 1mm of wire tips as shown in Figure 5.

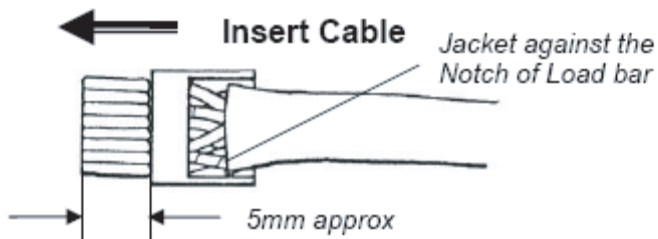

Figure 4

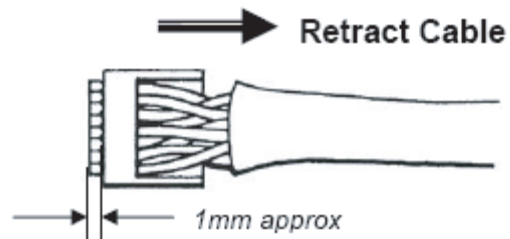
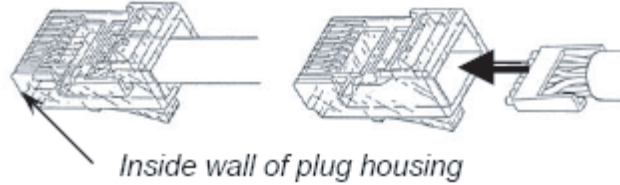

Figure 5

INSTALLATION (continued)

Insert the wired load bar into the RJ45 plug all the way until the wire tips are sealed against the inside wall of the plug housing (Figure 6).



IMPORTANT – No wires should be exposed when the plug is fully in place.

Figure 6

Terminate the cable and the RJ45 plug with a modular plug termination tool similar to the one shown in Figure 7.

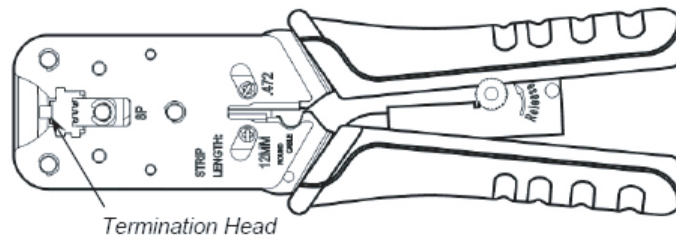

Figure 7

Depress the locking tab of the RJ45 plug and align it with the wide slot of the plug housing shown in Figure 8 Detail A. Gently pull the cable until the plug is fully seated. Hold the plug in position and rotate cable fitting until tightened to a torque of 3.4 Nm (30 lb-in) as shown in Figure 8 Detail B.

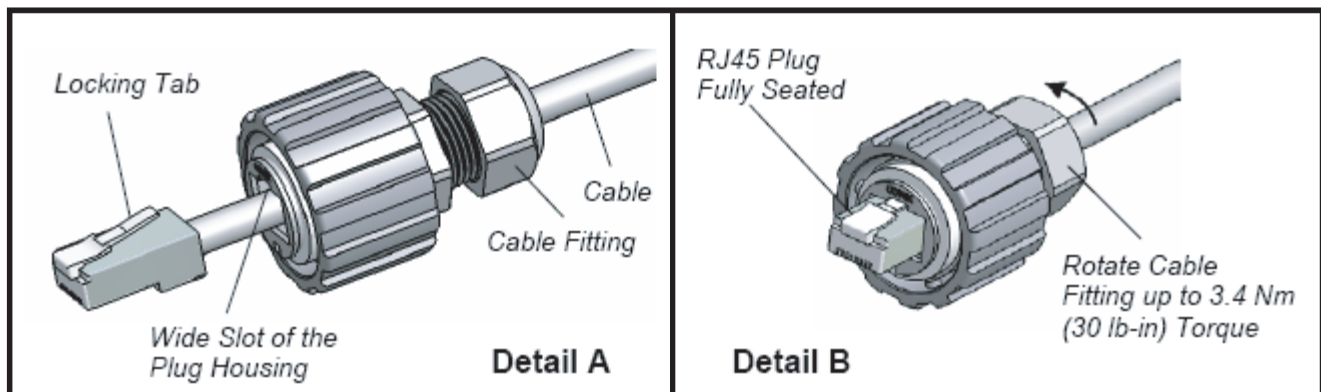

Figure 8

INSTALLATION (continued)

Once the quick connector assembly is completed attach the cable to the sensor. Remove the protective cover from the sensor receptacle assembly (Figure 9) by gently rotating the cover counter clockwise. Gently insert the assembled plug (Bayonet) into the jack adaptor of the RJ45 receptacle, align the 3 keys of the bayonet coupling ring with the 3 channels of the receptacle, and rotate the bayonet coupling ring until the 3 keys “click” into the bayonet channels (Figure 10).

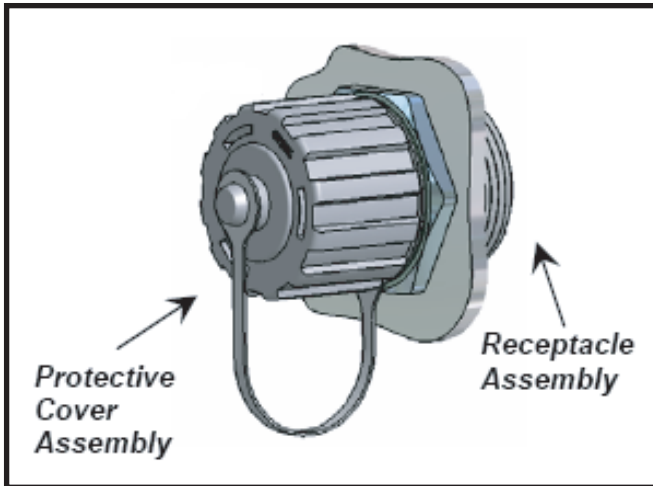

Figure 9

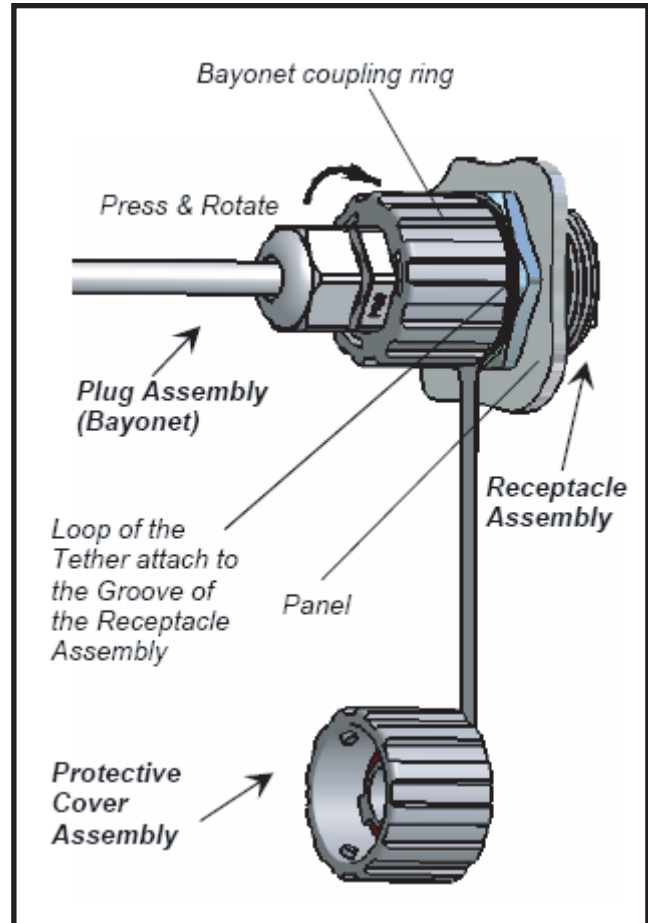

Figure 10

INSTALLATION (continued)

INTERFACE CARD INSTALLATION:

Route the other end of the Ethernet cable to your cabinet. Connect the Ethernet connector to the end of the cable. Configure the Ethernet connector (RJ45 plug) for a “Straight thru” connection.

EIA/TIA 568B WIRING STANDARD	
PIN	WIRE COLOR
1	White w/ Orange Stripe
2	Orange
3	White w/ Green Stripe
4	Blue
5	White w/ Blue Stripe
6	Green
7	White w/ Brown Stripe
8	Brown

Figure 11

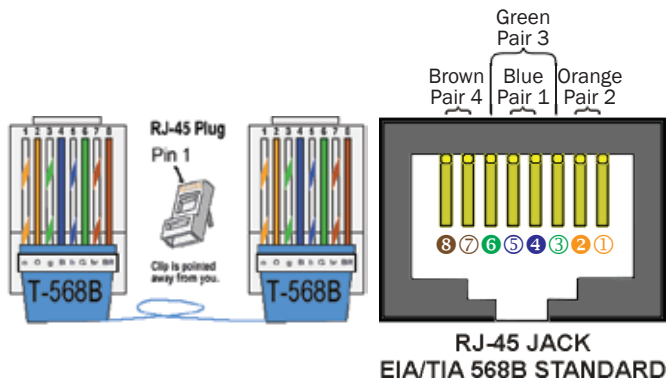

Figure 12

NOTE: Your colors may be different than what is shown.

After completing the Ethernet cable, plug the interface card into your traffic cabinet.

- If using the 4 output interface card, ensure that it is plugged into the even slot.
- If using the 2 output interface card, it can be plugged into any slot.

Either card uses 12-24 Volts supplied by the rack in the cabinet.



CAUTION: Power supply must be capable of supplying 1 amp of current to each TCIB card.

Once the interface card is properly installed, plug the Ethernet cable from the sensor into the setup port of the card. Initially the LEDs will light and stay on when the Ethernet cable is plugged into the setup port. This is normal and indicates that the unit has not been completely setup. Once a valid connection is established the LED will light only when the zone is activated by vehicle detection. The sensor is now ready to program.



SOFTWARE SETUP:

Programming of the INTERSECTOR is performed by connecting the sensor to a computer. Connect a Laptop/PC to the Laptop Ethernet port.



WARNING: The INTERSECTOR can only be programmed if the Ethernet cable is plugged into the setup port on the interface card. Please ensure proper connection before proceeding further.

INSTALLATION (continued)

When the sensor is connected to the setup port, it will receive power from the interface card.

Set your computer for a Dedicated IP Address:

1. Select the START button at the lower left of the computer screen.
2. Select SETTINGS and open CONTROL PANEL.
3. Select NETWORK AND DIAL UP CONNECTIONS (NETWORK AND SHARING CENTER for Vista, NETWORK AND SHARING for Windows 7).
3b. For Vista, choose MANAGE NETWORK CONNECTION. For Windows 7, select CHANGE ADAPTER SETTINGS.

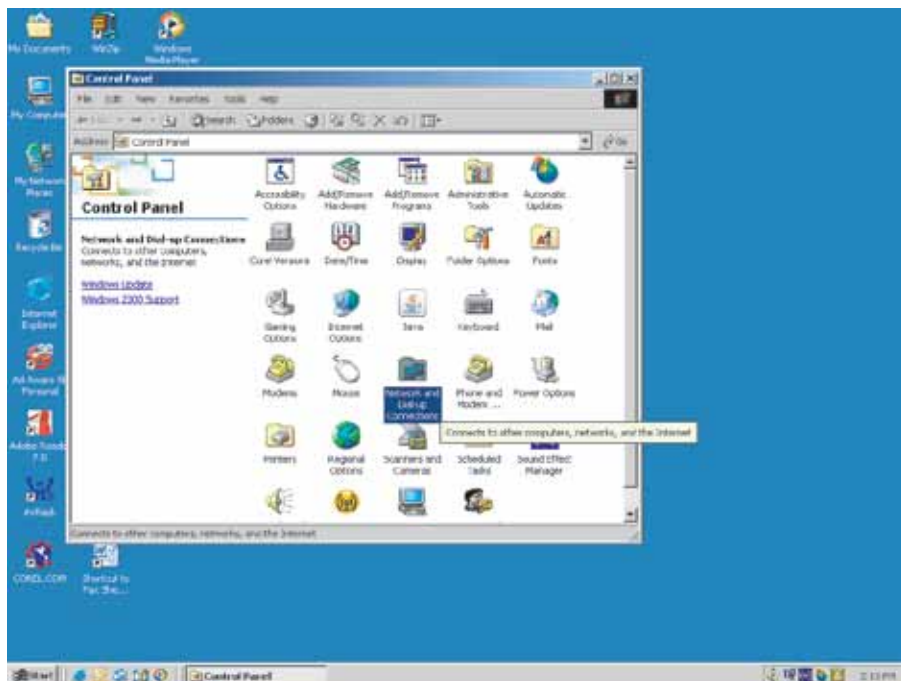

4. Select Local Area Network.
5. Click on Internet Protocol TCP/IP (Internet Protocol version 4TCP/IPV4 for Vista or Windows 7).
6. Select Properties.

INSTALLATION (continued)



7. Select Use the following IP address.
8. For IP address, enter the following: 192.168.0.99
9. For Subnet Mask enter the following: 255.255.255.0
(NOTE: When you are finished installing the INTERSECTOR, it will be necessary to return to Properties and select “Obtain an IP address automatically” to restore default port settings.)

Click OK to save changes and close the network window.



WARNING: DO NOT REFRESH your internet browser after entering IP Address. Always enter the IP Address manually.

Programming The INTERSECTOR:

On your computer, open an Internet browser (Internet Explorer version 7 or greater is preferred). In the Address bar of the internet browser type [HTTP://192.168.0.100](http://192.168.0.100). This should connect the computer to the sensor. You will be prompted for a password. The default password is “password”. After the password is accepted the start page for sensor setup will be displayed.

If you wish to change **VEHICLE MAX PRESENCE** time from the default setting of 240 seconds, choose **SETUP**.

Enter the desired value (0 - 960 seconds) in the window next to **VEHICLE MAX PRESENCE** time. Click on **VEHICLE MAX PRESENCE** time to store the value. Click on **BACK** to exit the Setup menu.

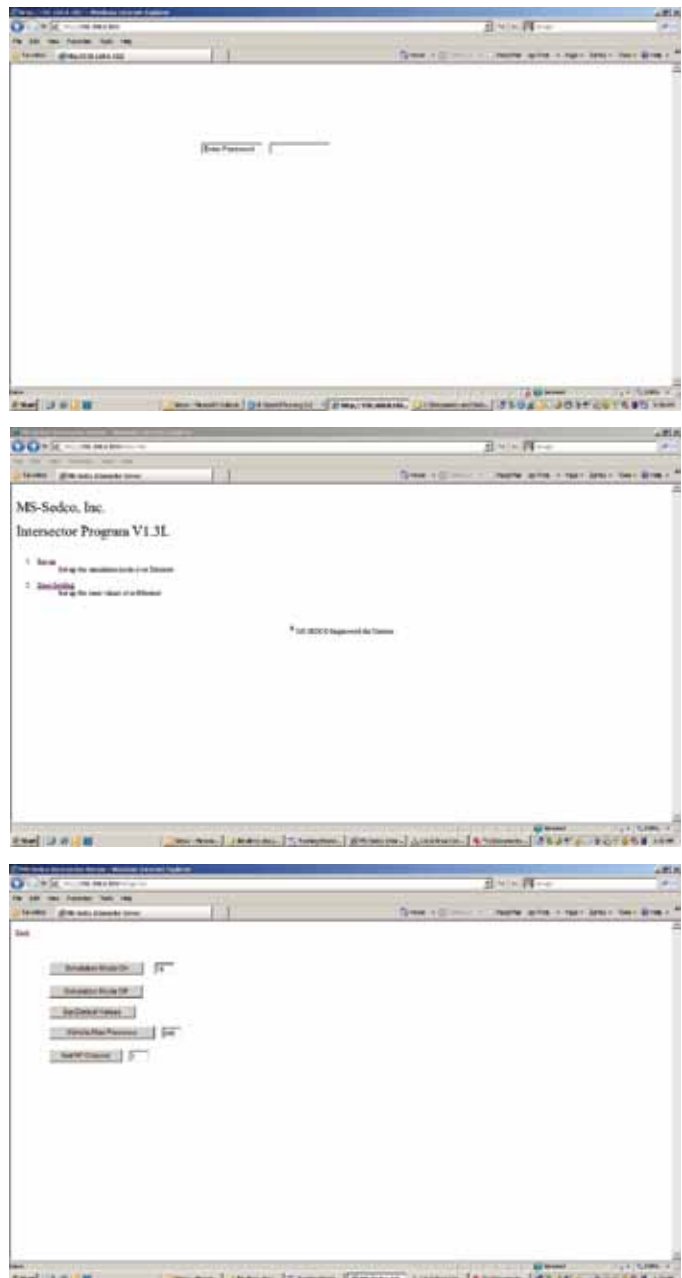

INSTALLATION (continued)

Select ZONE SETTING (METER) or ZONE SETTING (FEET). This will open the programming screen for the INTERSECTOR. (Note: When you enter dimensions in one unit the numbers are also stored for the other unit. This means that if someone installs the unit in meters, you can open it with feet, and the units will be correct.)

Upon entering the programming screen you will see the Target Setup Table, Data Display, and Vehicle Table.

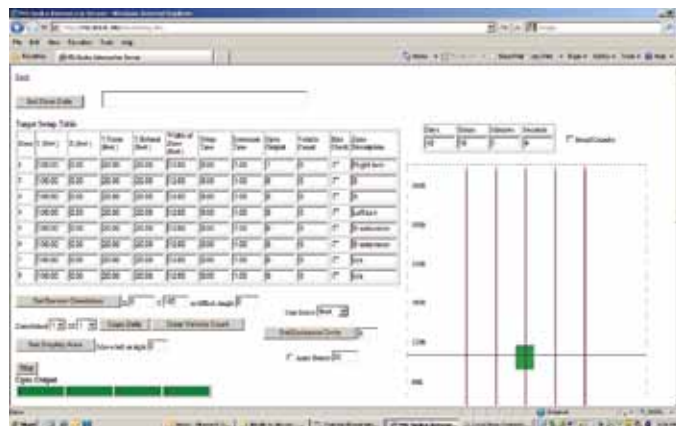

You will see vehicles passing through the Data Display (right half of screen). If you do not, confirm the alignment of the sensor. To track the pattern of the vehicles being displayed, turn on BREAD CRUMBS.

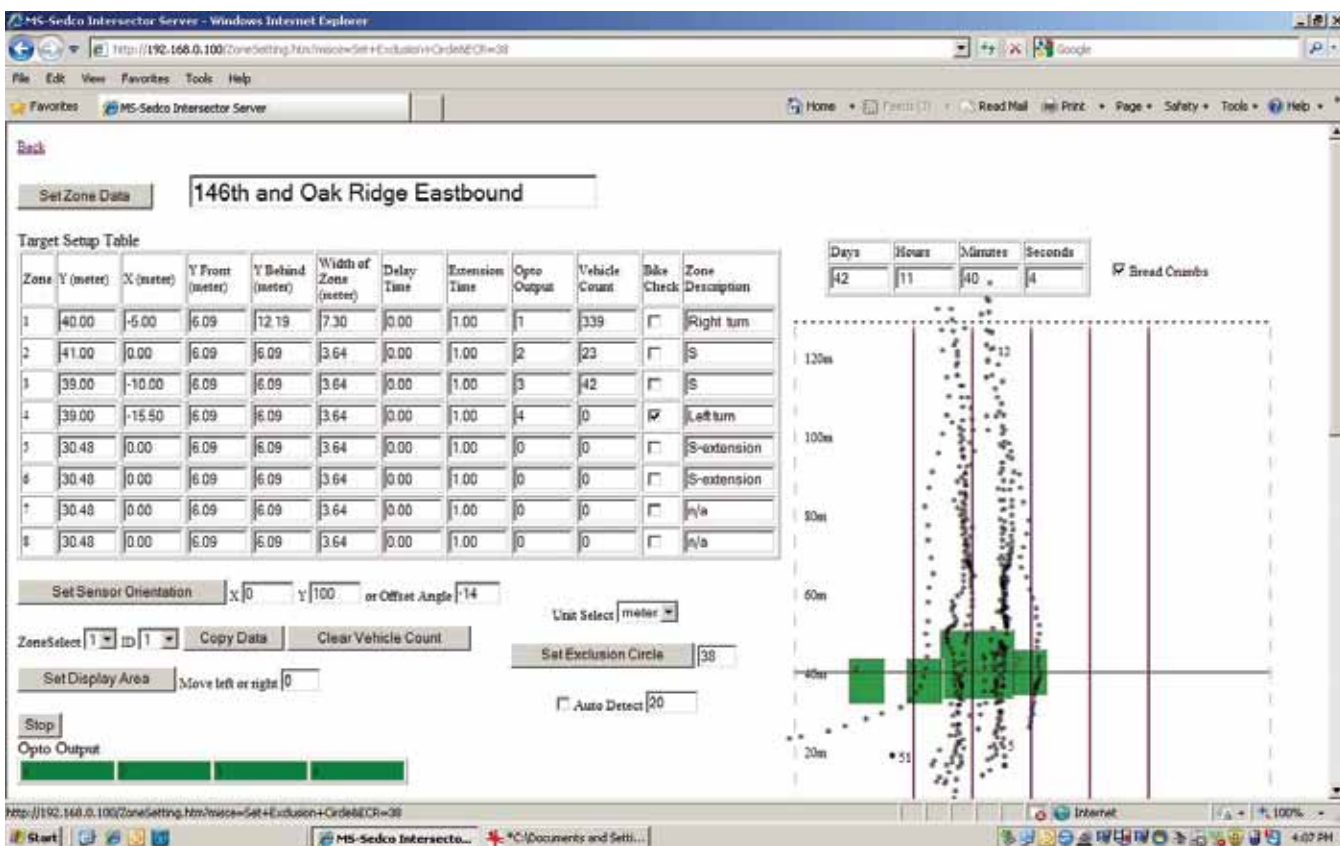

INSTALLATION (continued)

Refer to your completed INTERSECTOR Worksheet and enter the Offset Angle or dimensions to the center of the stop bar zone. Click on SET SENSOR ORIENTATION to save the value. This should correctly align the vehicles passing through the stop bar area on the graphics portion of the screen (right side).

Turn on Bread Crumbs by clicking the box in the upper right portion of the screen. Use the Bread Crumb graphics to ensure that the sensor is aligned properly. If the Bread Crumbs for the left or right turn lane are ending early, adjust the sensor side to side until the desired tracking is displayed. If the bread crumbs for the straight lanes are ending early or extending too far, adjust the tip angle up or down slightly. Fine tune the offset angle so that the path of vehicles aligns with the vertical lines displayed. Note that these lines do not represent lanes, but are merely to be used for alignment purposes. If you are working with a curved road, look for alignment in the stop bar area only.

SETTING UP DETECTION ZONES:

If this is your first time setting up an INTERSECTOR, you can explore its capabilities in Simulation Mode. Please refer to Appendix A for more information.

The best way to set up detection zones is to base your zones off of real traffic. When a car is in a desired zone, click the Stop button.

Next, refer to the Vehicle Table and locate the desired ID to copy. The vehicle number should match what you see in the Data Display.

On the Zone Select line of the webpage, choose the zone that you want to set up (Zone 1 is the default). Then choose the ID that you selected in the previous step. Note that this is the ID number, not the Vehicle number. Then click COPY DATA, and the zone should appear in the graphics portion of the screen. A stop bar graphic will appear at the front of Zone 1.

Now it is time to fine tune the zone. To extend the zone farther forward, adjust Y Front entry (20 feet is the default value). To extend the zone farther back, adjust the Y Behind value (20 feet is the default value). To widen or narrow your zone, adjust the Width of Zone entry (12 feet is the default value). If you have adjacent zones, we recommend leaving no gap between them - even a little overlap is OK. To apply delay time or extension time to a zone, enter values for those entries. Next, choose an output by entering a value for Opto Output (0-4). A value of zero will indicate this zone is turned off. No output will be sent for a vehicle detected within this zone. Finally, enter a description for the zone for future reference. Check BIKE ONLY to ignore cars and trucks that may be in the zone.

INSTALLATION (continued)

If you find that you need to move the overall location of a zone, you can move a zone to the left by decreasing the X value (note that X values may be negative in some cases). Increasing the X value will move the zone to the right. Decreasing the Y value will move the zone closer, while increasing it will move the zone farther away.

The new zone will show in yellow except when a vehicle is present. If a vehicle is present in a zone, the color changes to red. When you are satisfied with the location of your zone, click on SET ZONE DATA near the upper left of your screen. At this point, the yellow zone will turn green, indicating that it is saved to memory. You will also observe traffic again in the Data Display and in the Vehicle Table.

Repeat the previous steps as necessary to create additional zones.

We recommend observing traffic for a short while to observe that all zones are operating as intended. Bread crumbs may be beneficial for making these observations. Make any adjustments to the dimensions of the zones if necessary. Any zones being altered will turn back to yellow instead of green when no vehicle is present. Click SET ZONE DATA to save your changes.

To save your setup to file, follow these steps:

- Click on SET ZONE DATA to store your setup in the Intersector.
- Select FAVORITES on the Toolbar at the top of your internet browser.
- Select ADD TO FAVORITES, name the setup (possibly the direction of traffic at this intersection such as Westbound), and create a new folder to store this favorite in, such as the intersection name (Main and 1st street).
- You can also copy the website link from the address bar and paste it to a Word document. This Word document can then be saved as a file. We recommend naming the file with the intersection and direction name (MainFirstWestbound.doc).

When you are satisfied with your settings and ready to enter operational mode, click on BACK at the upper left. Please note that if you haven't clicked SET ZONE DATA, one or more of your changes may not be saved.

ADJUSTMENTS

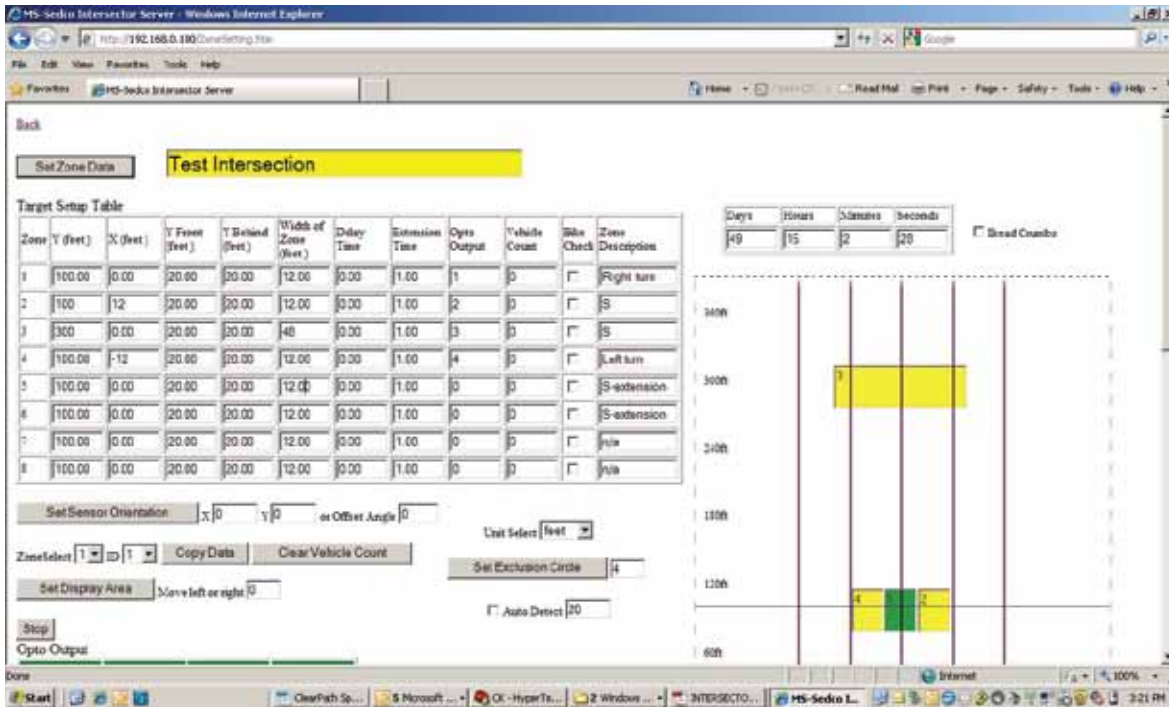

Observe the location that the zone is shown on the Data Display. If the zone needs to be moved or resized, use the following guidelines:

- To move the zone left, The X coordinate value should be decreased. If necessary, the value can be negative. (Example: -38.00)
- To move the zone right, the X coordinate value should be increased.
- To move the zone farther away (up on the screen), the Y coordinate value should be increased.
- To move the zone closer (down on the screen), the Y coordinate value should be decreased.
- To make the zone wider or narrower, increase or decrease the value for Width of Zone.
- Increasing or decreasing the values for Y Front or Y Behind will lengthen or make the zone shallower.

OPERATIONAL MODE:

Unplug the Laptop Ethernet cable from the Laptop Ethernet Port. Move the Sensor Ethernet cable to the Operational Ethernet port. The green LED indicating connection and the yellow LED indicating data should be on. The 2 or 4 LED for outputs will turn off when a valid connection has been established to the sensor. Confirm operation of each zone. Ensure that the appropriate LED light up when detection occurs.

CHANGING THE INTERSECTOR IP ADDRESS

Software for the INTERSECTOR and TCIB has been updated to allow the system to be IP addressable. Any INTERSECTOR units shipped with rev K software are IP addressable. Older units that have rev F software must be upgraded to be IP addressable. For instructions on updating software, please contact MS Sedco.



WARNING: If you plan to change IP Addresses on the INTERSECTOR and TCIB for use with a local network, please maintain a record of the new IP Addresses and passwords. If you do not have access to the IP Addresses and passwords it will be necessary to connect to the INTERSECTOR and TCIB to obtain this information.



WARNING: If you are setting up an Ethernet switch or multi-port hub to access the INTERSECTOR it is important to use a modified Ethernet cable between the “Operational” port of the TCIB and the switch or hub. This cable should be modified to ensure voltage is not transmitted to the switch or hub. Ethernet Switch Safe cable is available from MS Sedco. To construct one of the cables it is necessary to disable pins 4, 5, 7, and 8.

To change the IP addresses on the INTERSECTOR or TCIB, it is first necessary to know the current IP addresses. The default IP Addresses are:

Default Addresses:	
INTERSECTOR IP	192.168.0.100
TCIB card	192.168.0.98
TCIB gateway	192.168.0.1
Computer	192.168.0.99
Computer subnet mask	255.255.255.0
Computer Gateway	192.168.0.1

To find out which version of software the INTERSECTOR and TCIB has, follow these instructions:

Verifying software version for TCIB and INTERSECTOR:

To verify the software version of the INTERSECTOR:

- Set laptop IP address to 192.168.0.99 in the LAN properties of the TCP/IP as shown on pages 11 and 12 of the INTERSECTOR Installation Instructions. Connect laptop to the TCIB “Laptop” port. Move INTERSECTOR Ethernet cable from “Operational” port to “Setup” port. Access the default web page at address 192.168.0.100. Note that if your sensor has version K or better software, you will be prompted for a password. The default password is “password”. The software version should be shown as V1.3K, where K is the software revision. **NOTE:** If IP Addresses have previously been changed, it will be necessary to use the new IP addresses to access the INTERSECTOR.

CHANGING THE INTERSECTOR IP ADDRESS (cont.)

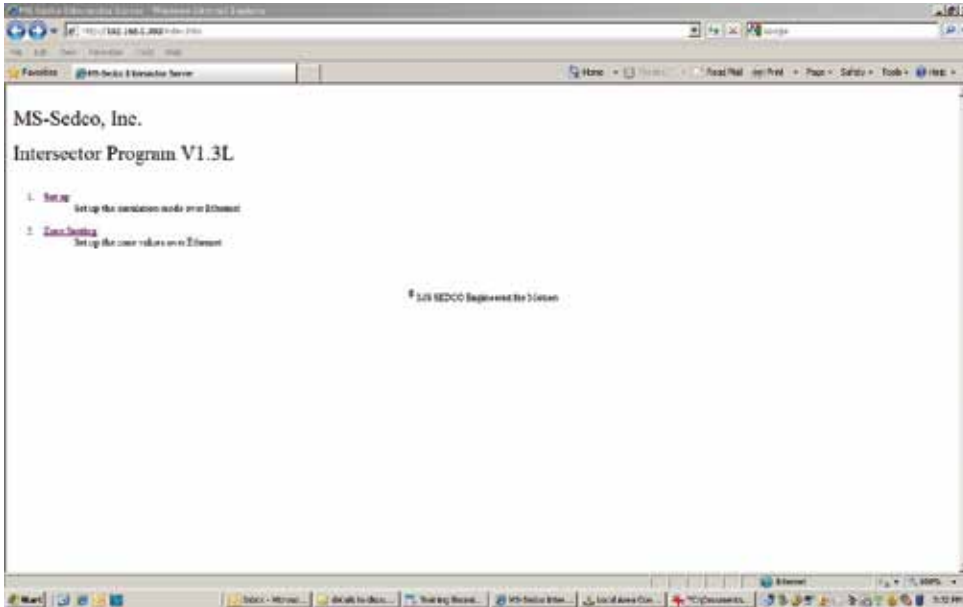

To verify the software version of the TCIB:

- Connect the laptop to TCIB RS232 port. This can be accomplished by using a USB to RS232 adaptor. Using the communications program Hyperterminal, which is supplied with Windows up to version XP, you can connect to the TCIB. If you are using Windows 7 you will need another communications program. For instructions on using Windows 7, please refer to Appendix C at the back of this manual.
- Open Hyperterminal by clicking on “Start” at the bottom right of your screen. Select “Programs” then “Accessories” and then “Communications”. Hyperterminal should be listed there.

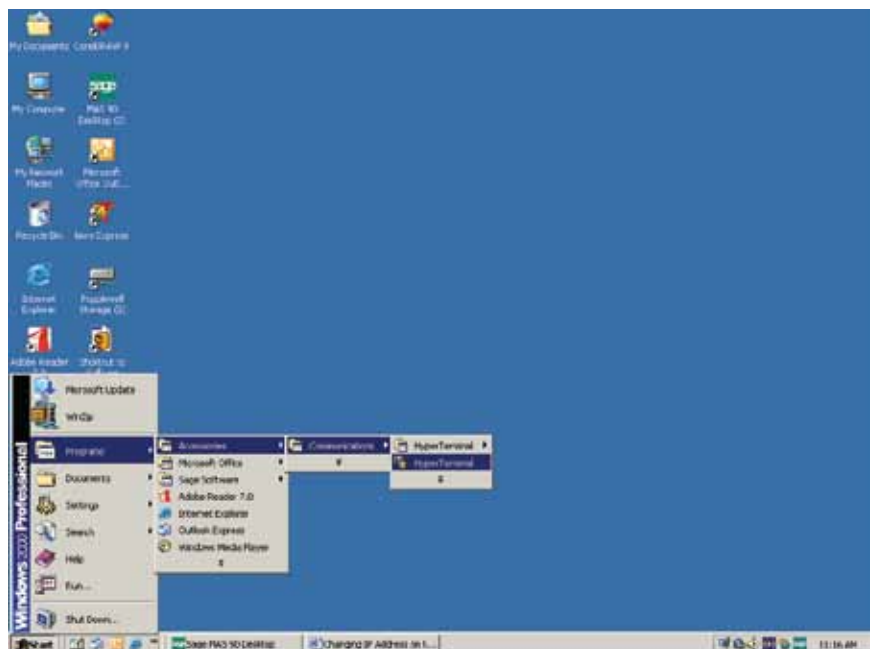

CHANGING THE INTERSECTOR IP ADDRESS (cont.)

Once you have opened Hyperterminal you must configure it for use with the TCIB or INTERSECTOR. You can either create a new connection when prompted, or you can select “File” then “Properties”. Select the COM port the RS232 is connected to on your laptop and select “Configure”. Enter the following settings:

- Bits per second: 115200
- Data Bits: 8
- Parity: None
- Stop Bits: 1

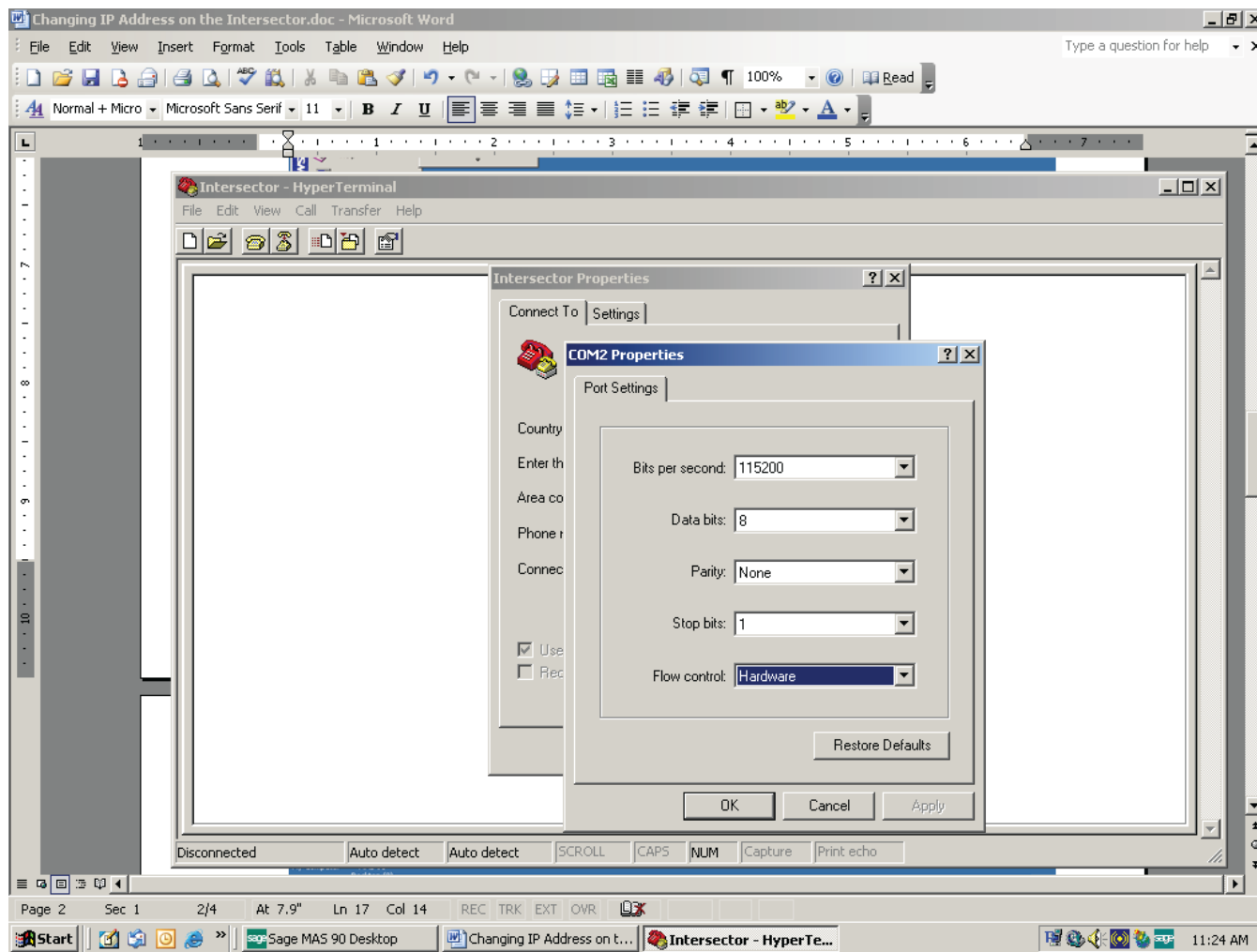

CHANGING THE INTERSECTOR IP ADDRESS (cont.)

Once you have configured Hyperterminal you can connect to the TCIB by clicking the reset button on the TCIB or powering the TCIB while Hyperterminal is running. If you connect to the TCIB you can see this screen:

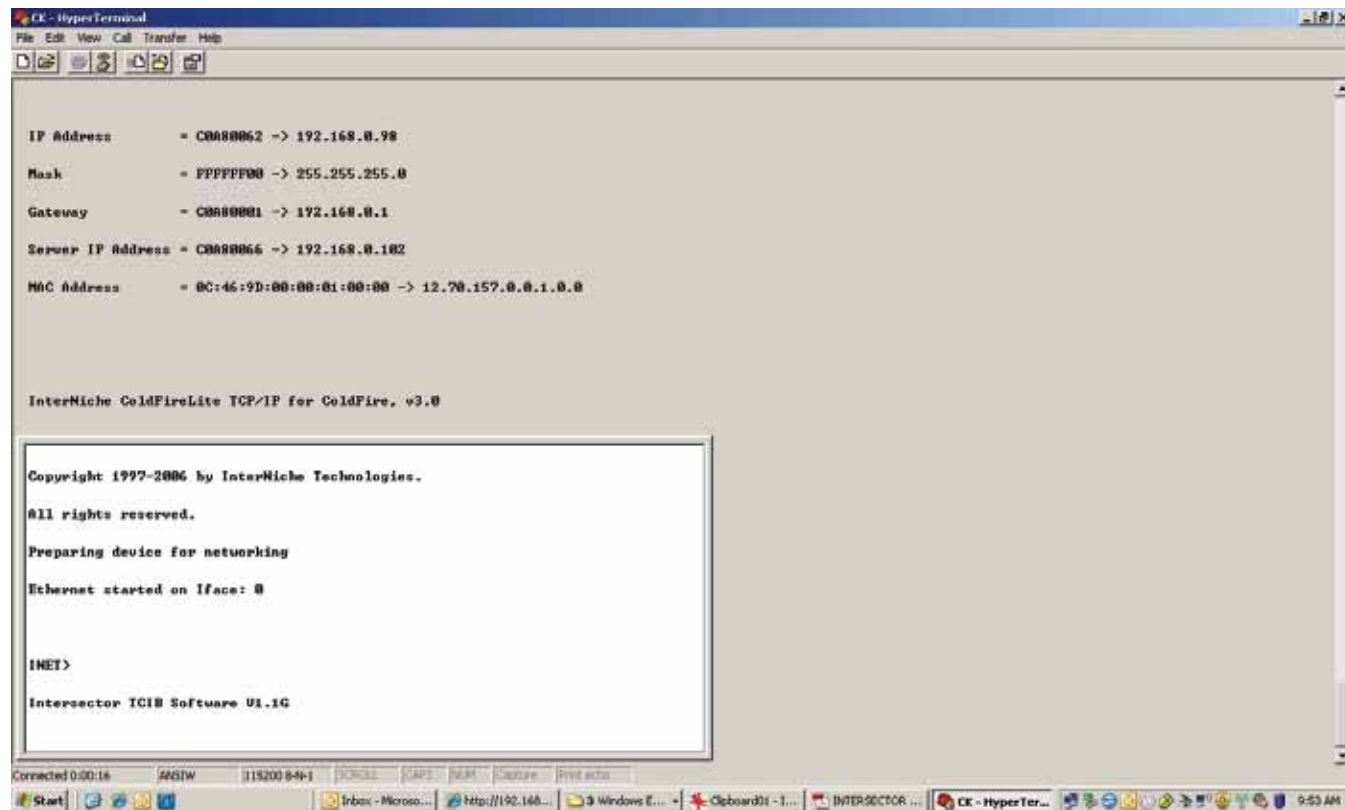

The bottom line from the Hyperterminal screen shows the TCIB software as version F. The screen also shows the IP address for the TCIB. Record this value for use in the next section.

Checking or setting IP Address

To check or set IP addresses you need to use a software program called `IP_Address_Set.exe`. This program is available as a zip file (`IP_AddressSet_V1.2.zip`) on our website www.mssedco.com. Instructions on extracting the file to your computer also appear on the website.

Once you have extracted the files, run `Setup.exe` to finish the installation of the program.

There are several steps to changing the IP addresses on the INTERSECTOR, TCIB, and laptop. The steps would be:

- Confirm IP addresses in each device. Record these values for later use.
- Set up the TCP/IP on your computer as shown on pages 11 and 12 of this manual.

CHANGING THE INTERSECTOR IP ADDRESS (cont.)

- Connect to the TCIB via RS232 cable.
- Change TCIB IP address using the IP_Address_Set program.
- Connect to the Intersector via Ethernet cable.
- Use the IP_Address_Set program to change Intersector IP address
- Verify that changes match between Intersector and TCIB.
- Confirm you can access this address by opening the webpage using the new IP address.

To confirm or set the IP address on the TCIB, connect the laptop to the TCIB via RS232. Connect the laptop to the laptop port of the TCIB via Ethernet cable. Connect the Intersector Ethernet cable to the Setup port of the TCIB. You can also connect to the Intersector and TCIB via Ethernet switch or hub. The Intersector should be connected to the TCIB Setup port via Ethernet cable, and the TCIB Operational port should be connected to the Ethernet switch or Hub.

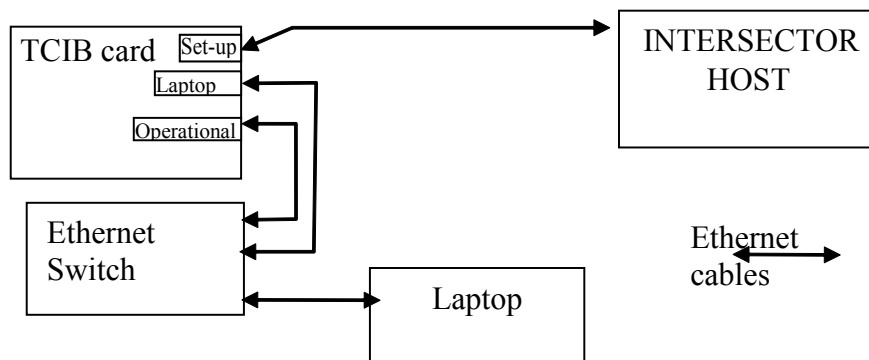

WARNING: Ensure that the TCIB “Operational” port is connected to the Ethernet switch or hub with the cable labeled “Ethernet Switch Safe” or that the cable has been modified to disable voltage lines.

Open the default webpage (192.168.0.100) and note you are challenged with a password. Run “IP_Address_Set.exe”. On the INTERSECTOR tab under the Connection Select mark “Internet” since you are connecting via Ethernet cable. Ensure that the correct INTERSECTOR IP Address is shown in the box next to the “Connect Internet” button. Click on the “Connect Internet” button. A message will be displayed to show you are now connected to the INTERSECTOR.

To retrieve a misplaced password:
Select “Read Password”. When the password is read, the program will display the message “Read Password Finished”.

CHANGING THE INTERSECTOR IP ADDRESS (cont.)

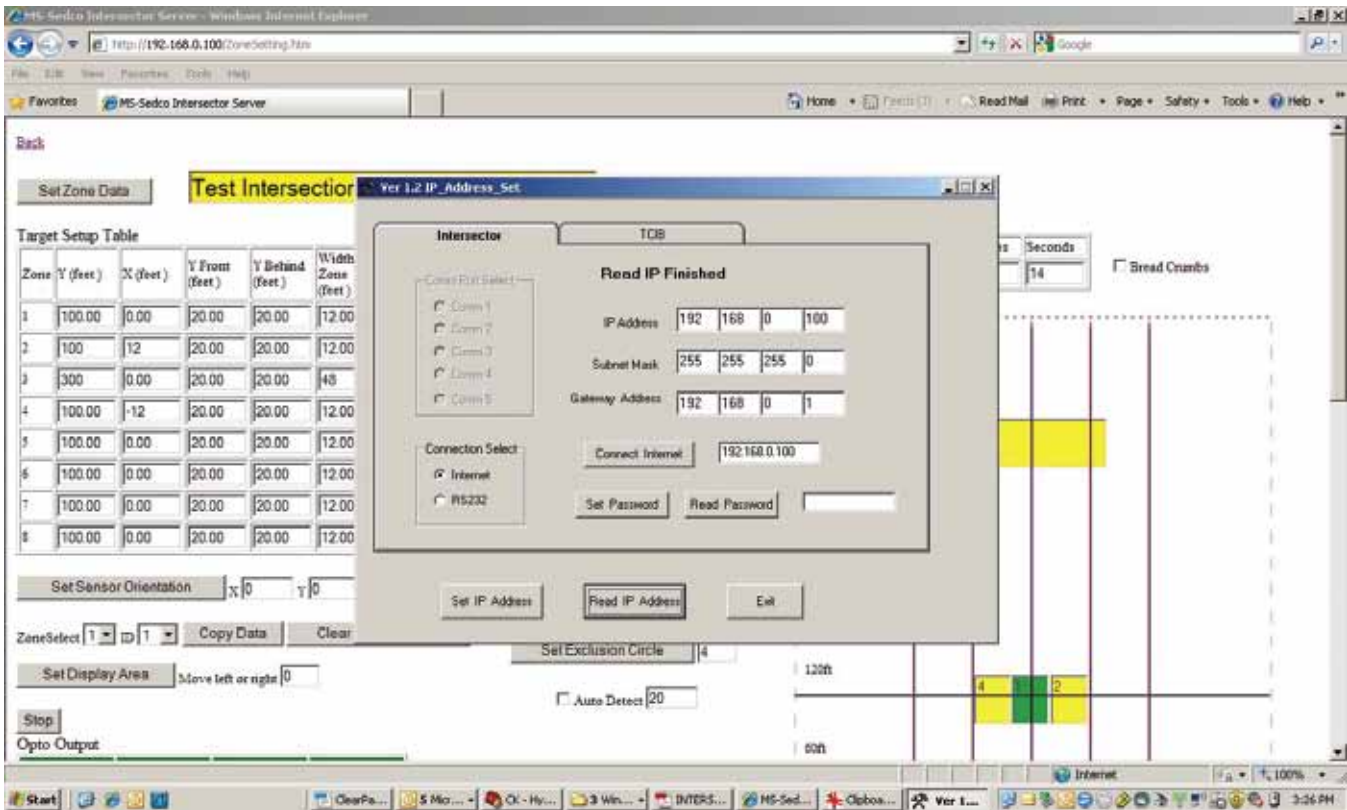

To confirm TCIB IP address:

Refer back to the IP address from Hyperterminal in the previous section. If you need to confirm IP address again, connect laptop to TCIB via RS232 cable. Run Hyperterminal or use IP_Address_Set to access the TCIB. If using IP_Address_Set select the TCIB tab. Select the COM port that corresponds to the RS232 cable. Select “Read IP Address”. The IP address for the TCIB should be displayed.

To change INTERSECTOR IP Address:

When changing IP Address it is first necessary to determine the new addresses to be used. For an example, we will use the following IP Addresses:

The new addresses we want to change to are:

- INTERSECTOR IP 10.230.39.230
- TCIB card 10.230.39.231
- Gateway 10.230.32.1
- Computer 10.230.32.51
- Computer subnet mask 255.255.240.0
- Gateway 10.230.32.1

CHANGING THE INTERSECTOR IP ADDRESS (cont.)

To set the IP Address on the INTERSECTOR, connect the laptop to the laptop port of TCIB and the INTERSECTOR to “Setup” port of the TCIB, both via Ethernet cables. You can also connect to the INTERSECTOR via Ethernet switch or hub. The INTERSECTOR should be connected to the TCIB “Setup” port, and the TCIB “Operational” port should be connected to the Ethernet switch or hub.

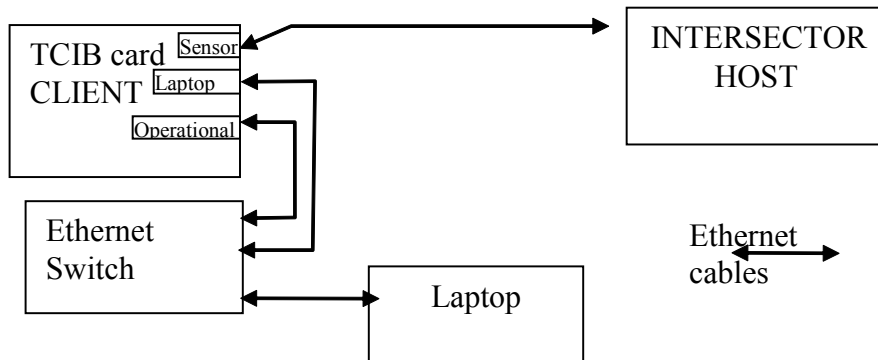

Run `IP_Address_Set`. You should see the following screen:

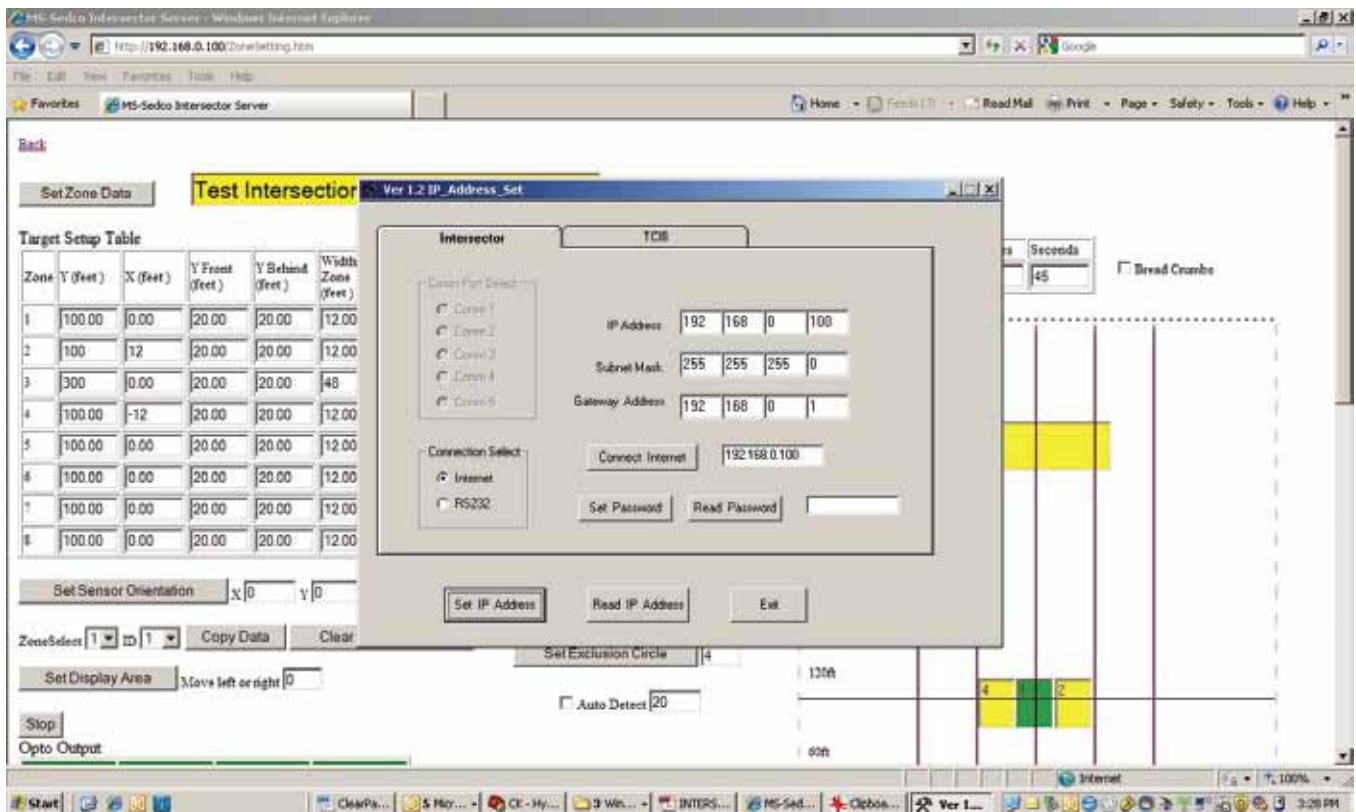

CHANGING THE INTERSECTOR IP ADDRESS (cont.)

Enter the new IP address, Subnet Mask, and Gateway address, then click “Set IP Address”.

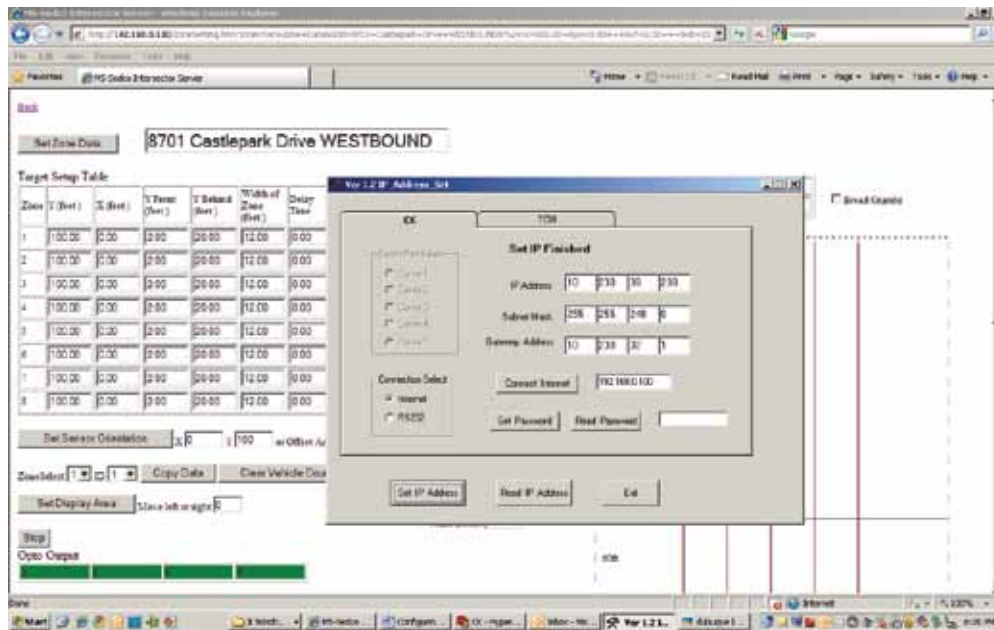

The next step is to set the IP address for the TCIB via the RS232 cable. With the TCIB connected to the laptop via the RS232, run IP_Address_Set. Choose the TCIB tab and select the correct Comm Port. Click “Read IP Address”. Change the information in boxes to reflect the new IP address, Subnet Mask, Gateway address, and Intersector IP address. Click “Set IP Address” and wait until the message “Set IP Address Finished” is displayed.

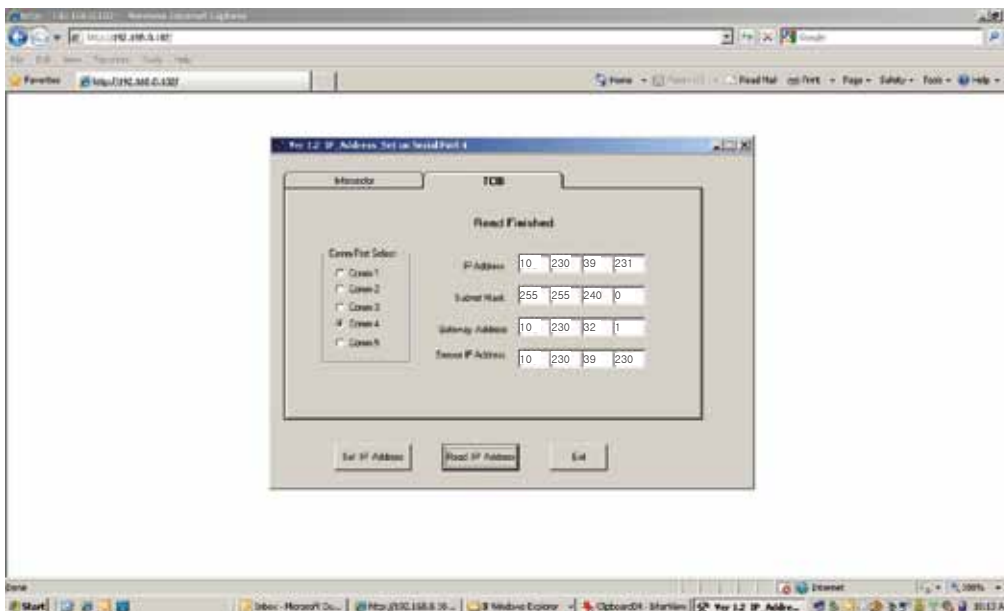

CHANGING THE INTERSECTOR IP ADDRESS (cont.)

After changing the IP address you must setup your laptop for this gateway:

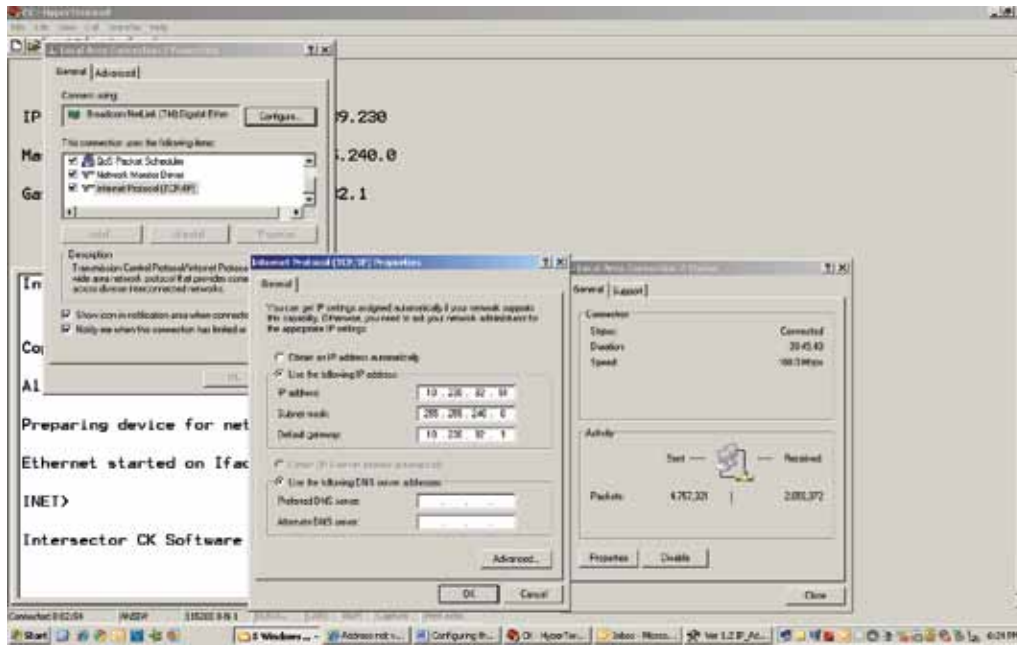

Verify the setup by connecting to the INTERSECTOR via the new IP address:

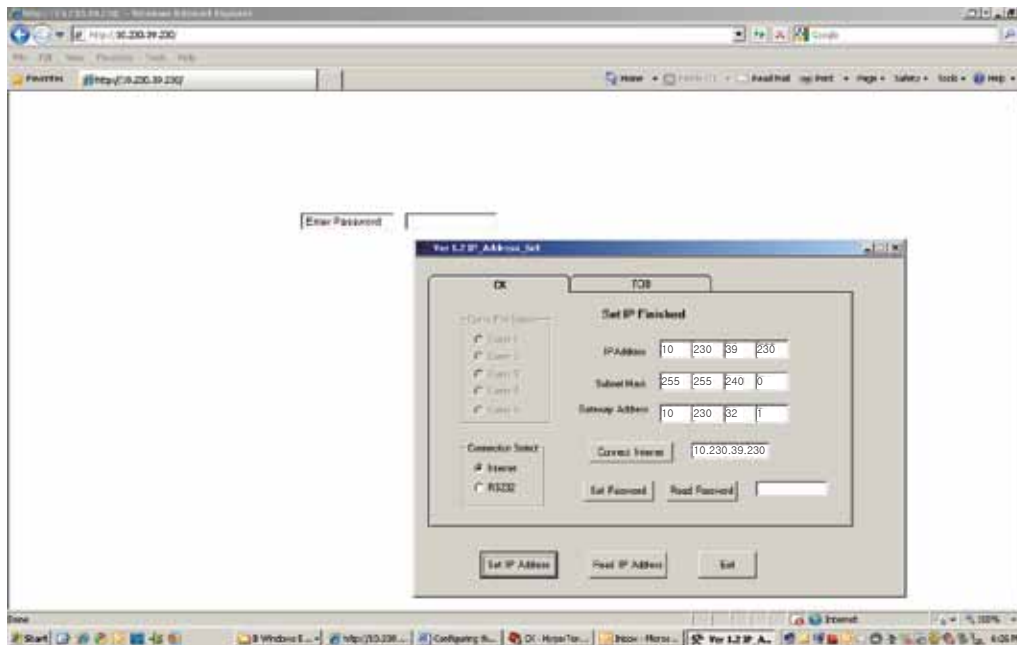

THEORY OF OPERATION

The INTERSECTOR sensor uses FSK microwave radar to identify, classify, and track vehicles by position and speed. This information is overlaid in an X-Y coordinate system, allowing users to set up detection zones. Presence of a vehicle in a user-defined zone will produce an output to the control output. Users are able to set a maximum presence time, and associate unique outputs, time delays, or output delays with individual zones.

The interface board monitors whether the sensor is functioning, and provides a means for end users to set up zones via a connection to a laptop computer. It also provides the outputs to the control panel, and includes LEDs which allow end users to verify operation without having to connect to the laptop.

MAINTENANCE

No regular maintenance of the INTERSECTOR is required. During the installation and setup of the INTERSECTOR, certain problems may occur. We have attempted to list some common problems and possible solutions. If you need further assistance while installing the INTERSECTOR, please contact MS Sedco Technical Support at (800) 842-2545.

DESCRIPTION OF PROBLEM	SOLUTION
When the TCIB card is plugged in the LED lights do not light up:	<ul style="list-style-type: none"> • Check for power to the TCIB board. • Verify that traffic is present in detection zones. Move Ethernet cable to setup port. Connect PC and verify zone location and sensor aim.
LED lights are always on:	<ul style="list-style-type: none"> • Prior to completion of setup the TCIB board will keep LED lights on as a “constant call”. Ensure that Ethernet cable is connected to operational port. Connect sensor to computer and setup zones.
Unable to see setup page when computer is connected:	<ul style="list-style-type: none"> • Check to ensure that Ethernet cable is connected to sensor • Check to ensure that Ethernet cable is plugged into Setup port and laptop is connected to laptop port of the TCIB board • With the Intersector installed and connected to your PC the Ethernet LEDs on the PC should show connection. One LED is connection and should stay on, and the other is data which should blink. • Ensure that laptop IP address is set to proper address (as detailed on Page 7 of installation manual) • Check LEDs on the TCIB card. If they are not on, the TCIB card is not functioning. • Check the Ethernet cable. Plug the cable from the sensor into the operational Ethernet port on the TCIB and see that the LEDs go out to ensure the sensor is functioning properly and there is Ethernet communication.
Once Ethernet connection is made, and you see the Zone Setup page on your PC you see a message at the top of the page that reads “Sensor Error”:	<ul style="list-style-type: none"> • There is a problem with the sensor that cannot be corrected in the field. Contact your distributor or MS Sedco for further information.

MAINTENANCE

DESCRIPTION (CONT.)	SOLUTION (CONT.)
Unable to detect any vehicles during setup process:	<ul style="list-style-type: none"> • Put unit in simulation mode to verify sensor operation. • Adjust aim of sensor. Sensor should be pointed toward the center of desired detection area and angled down slightly (2-3° typical).
Random numbers are being displayed in your browser:	<ul style="list-style-type: none"> • Exit current Internet Explorer window and open a new window.
There are errors in numbers displayed in your setup windows:	<ul style="list-style-type: none"> • Go to Setup Menu and click on SET DEFAULT VALUES.
Settings are not being saved properly:	<ul style="list-style-type: none"> • Make sure to wait on web pages to load fully before trying to save settings. Before clicking on additional buttons, ensure that current operations are completed.
Vehicles occasionally pass through zone undetected:	<ul style="list-style-type: none"> • Edit software zone settings. Lengthen zone settings to properly match desired detection areas. • Confirm that LEDs come on as expected when vehicles pass through the zones. Note that if the zone is set short, fast cars can “jump” over the zone due to the sample rate of the sensor (20 times per second).
Vehicles continue to be shown after they have departed:	<ul style="list-style-type: none"> • Adjust aiming of sensor to ensure that it is centered and tilted down at a slight angle.

PARTS LIST

- TC-CK1-SBE sensor
- TCIB 2.1 2-output single-slot interface board
- TCIB 4.1 4-output single-slot interface board
- TCIB 4.2 4-output two-slot interface board

ELECTRICAL INTERCONNECTION DETAILS & DRAWINGS

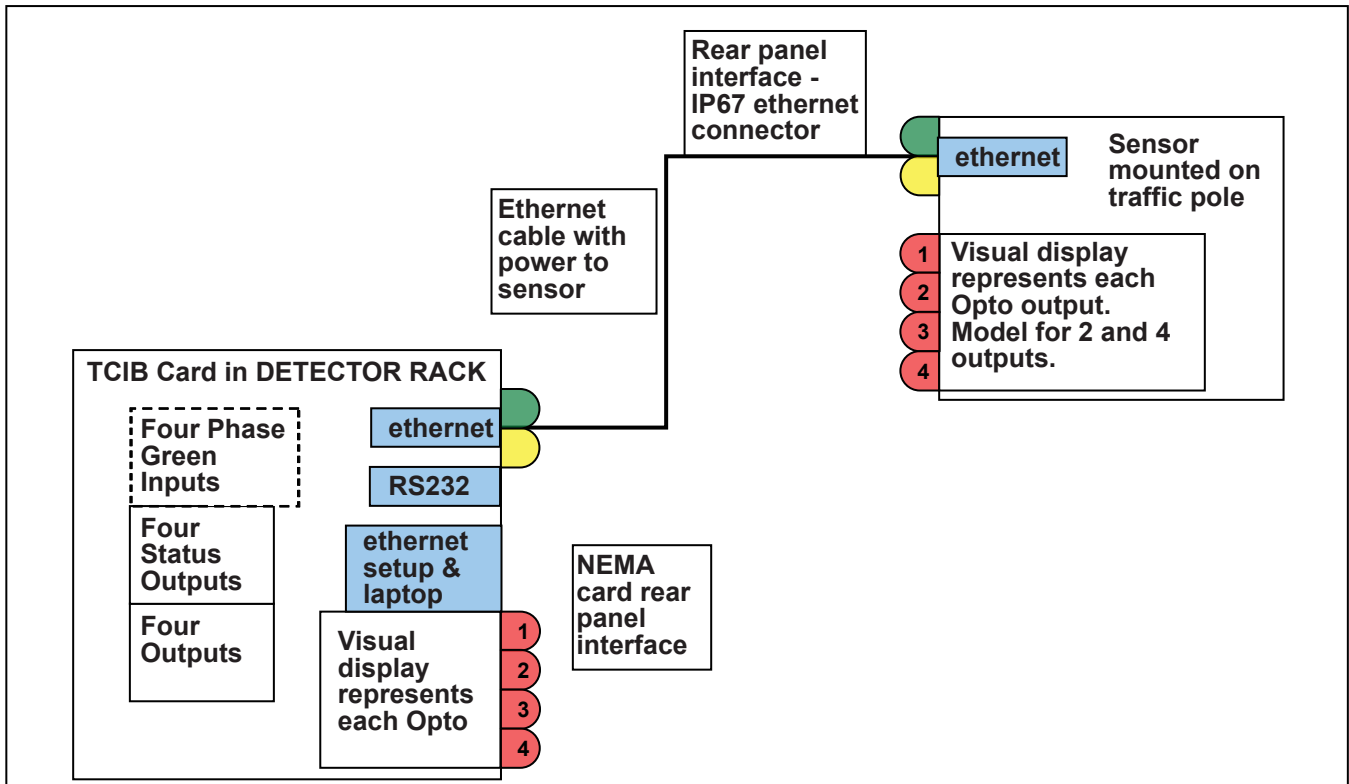

SCHEMATICS

Schematics will be supplied to governmental entities as required.

ASSEMBLY DRAWINGS

Assembly drawings will be supplied to governmental entities as required.

APPENDIX A: SIMULATION MODE

Simulation mode can be used to demonstrate the INTERSECTOR, confirm proper installation, or learn how to set up zones and use features. For first-time INTERSECTOR installers, simulation mode can be used to gain an understanding of the sensor setup and some of the sensor's operating characteristics.

To enter Simulation Mode, follow these steps:

Start with MAIN PAGE.

1. Click on **SETUP**.
2. Enter 1 for **SIMULATION MODE ON** and click on **SIMULATION MODE ON**. This enables simulation mode.
3. Click on **BACK**.
4. Click on **ZONE SETTING**. When this page loads you will see one vehicle pass through the grid.
 - a. Note the ID of the object increments by one each time.
 - b. Vehicles are sequentially numbered from 0 to 63 and then the numbering loops back to 0.
 - c. You can **STOP** the display to copy X and Y locations to any Zone. Vehicle tracking is fully working while the display is stopped.
 - d. You can set up a zone for this object manually. Note the zone turning yellow when you change any parameter on the zone. You must click on **SET ZONE DATA** or any changes are lost.
 - e. To use **AUTO DETECT** click on the check box when the vehicle is at the top of the grid. Note that as it goes through the stop bar the screen will freeze and update the angle. It will stay at zero since the vehicle is going vertically. The number 20 is the distance in front and behind the stop bar which INTERSECTOR uses to calculate and correct for angle of travel of cars. In other words it looks at Y =120 and Y=80 and using the X value for each point determines the offset angle to make cars go through straight. The value 20 can be reduced or increased but this is a good starting point. 10 may work better for smaller intersections.
 - f. The zone will begin working when you enter the X dimension for this vehicle. Note it is typically -16 feet for Zone 1. Enter this number (-16) for Zone 1 X cell. Click on **SET ZONE DATA**. Note the vehicle will go through the center of the zone now and Zone 1 counter will increment each time the vehicle goes through the zone. Opto output 1 will also turn red indicating detection.
5. Go back to **SIMULATION MODE ON** and enter 16. Click on back and then click on **ZONE SETTING**.
6. Now you will see 16 vehicles going through the grid. **NOTE:** in simulation mode, **VEHICLE MAX PRESENCE** Time is not valid and the objects stay on the screen forever.
7. Now we will shift the grid to show how to center the vehicles and then expand the grid to see zones in detail. Enter 100 for **Move Left Or Right**. Note the screen shifts right. The grids shift right also.

APPENDIX A: SIMULATION MODE (CONT.)

8. Check **BREAD CRUMBS**. Note the crumbs left as each car travels through. Uncheck and the crumbs disappear.
9. Open drop box for **FEET** and **METRIC** and chose **METRIC**. Note all dimensions have been changed to metric. If you save in metric and then go back to English you may have rounding errors (e.g. 100 feet will become 99.99).
10. Note the clock. This is an hour meter for **INTERSECTOR**. Time is saved every 30 minutes. If you unplug before 30 minutes it resets to zero again. If you unplug at 31 minutes it will reset to 31 minutes.
11. To add a second zone use **Zone 2** and enter 2 for **Opto output**. Enter 16 for **X** to center this zone on one lane of cars. Click on **SET ZONE DATA**. Note zone 2 is active and opto output 2 is active. Click on **SET ZONE DATA** to store this text.
12. Typical set up for a zone would be to overlap side by side zones by 1 foot. Adjust the **WIDTH OF ZONE** to get 1 foot overlap. The overlap is visible as darker area. If a vehicle enters that area both Zones will be activated.
13. To copy data, click on **STOP**. The vehicles will stop on the display but moving vehicles are still being tracked. Set **ZONE SELECT** to 3. Select **ID** to any vehicle you would like to set a zone at. Note that the **ID** number is different from the **Vehicle number**, which appears in the second column and in the chart. Note the **X** and **Y** position of this **ID** and then click on **COPY DATA**. Those **X** and **Y** values are now in the table. Set **Opto output** for zone 3 to 4. Click on **START**. Now you have created a new zone that will activate opto output 4. To take the unit back to its initial settings, go to **MAIN MENU**, click on **SETUP**, then click on **SET DEFAULT VALUES**. Upon returning to **ZONE SETTING**, all values should be back to factory settings.
14. When finished, click on **BACK**, then on **SETUP**, then on **SIMULATION MODE OFF**.

APPENDIX B: TCIB Connections

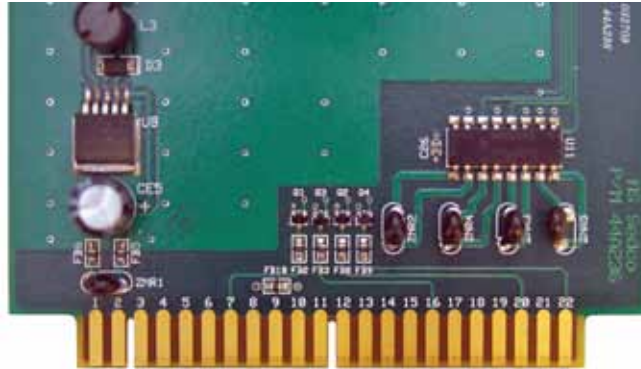

TCIB Pin Out (Blue active)

Pin	Function	Pin	Function
A.....	DC (-)	1	Chl. 1 Phase Green Input
B.....	DC (+)	2	Chl. 2 Phase Green Input
C.....	Reset Input	3	Chl. 3 Phase Green Input
D.....	Chl. 1 Loop Input.....	4.....	Chl. 1 Loop Input
E.....	Chl. 1 Loop Input.....	5.....	Chl. 1 Loop Input
F.....	Chl. 1 Out Drain.....	6.....	No Connection
H.....	Chl. 1 Out Source.....	7.....	Chl. 1 TS 2 Status Output
J.....	Chl. 2 Loop Input.....	8.....	Chl. 2 Loop Input
K.....	Chl. 2 Loop Input.....	9.....	Chl. 2 Loop Input
L.....	Chassis Ground	10.....	Chl. 4 Phase Green Input
M.....	No Connection	11.....	No Connection
N.....	No Connection	12.....	No Connection
P.....	Chl. 3 Loop Input.....	13.....	Chl. 3 Loop Input
R.....	Chl. 3 Loop Input.....	14.....	Chl. 3 Loop Input
S.....	Chl. 3 Out Drain.....	15.....	No Connection
T.....	Chl. 3 Out Source.....	16.....	Chl. 3 TS 2 Status Output
U.....	Chl. 4 Loop Input.....	17.....	Chl. 4 Loop Input
V.....	Chl. 4 Loop Input.....	18.....	Chl. 4 Loop Input
W.....	Chl. 2 Out Drain.....	19.....	No Connection
X.....	Chl. 2 Out Source.....	20.....	Chl. 2 TS 2 Status Output
Y.....	Chl. 4 Out Drain.....	21.....	No Connection
Z.....	Chl. 4 Out Source.....	22.....	Chl.4 TS 2 Status Output

APPENDIX C: Windows 7 Set-up

To complete Windows 7 Set-up, follow these steps:

- Select “Start” in the lower left corner of Windows 7.
- Select “Control Panel”.
- Select “Network and Sharing Center”.

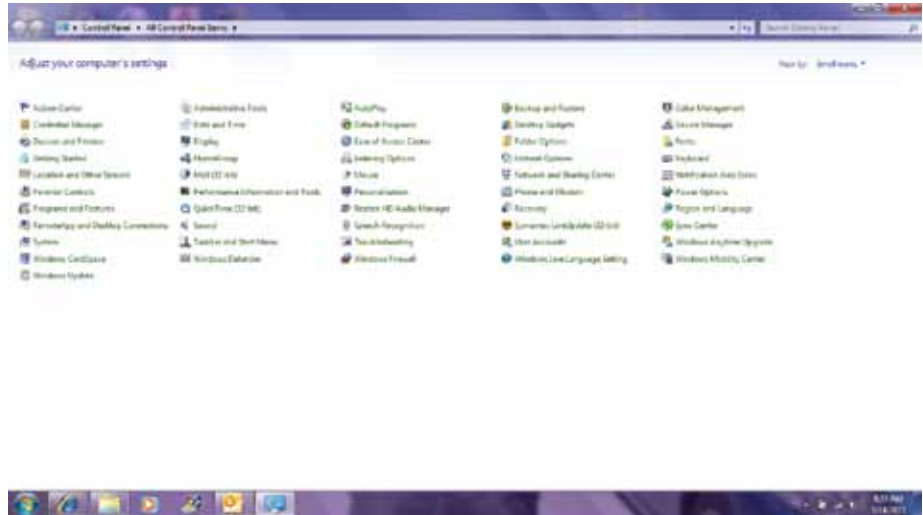

- Select “Change Adaptor Settings”.



APPENDIX C: Windows 7 Set-up

- Right click on “Local Area Connections”.

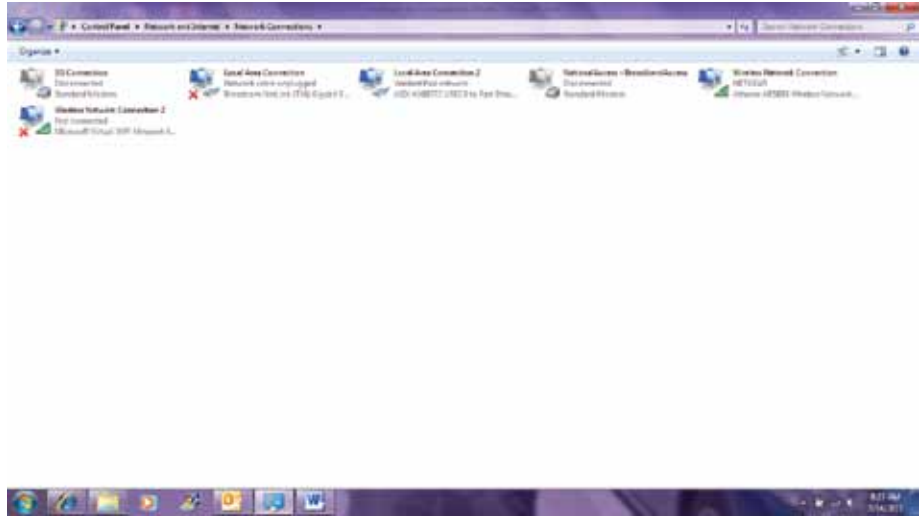

- Select “Properties”.

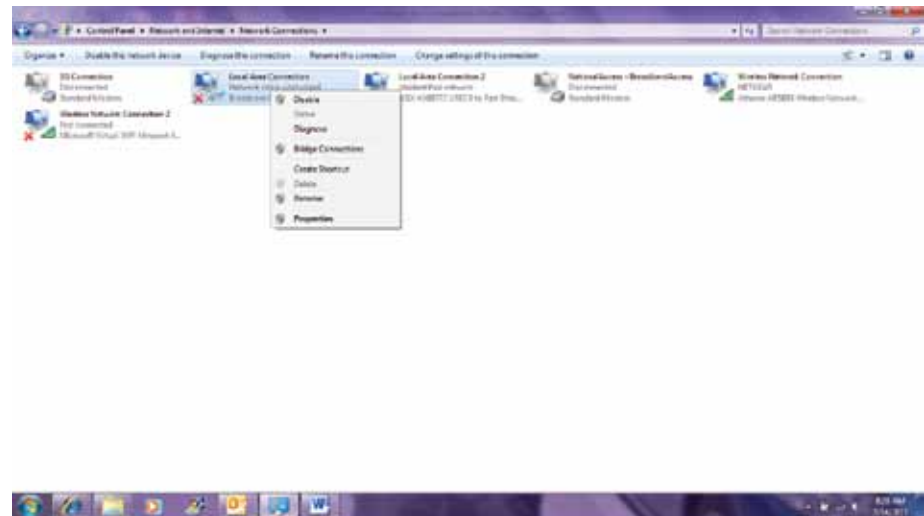

- Select “Internet Protocol 4 (Vers. 4).
- Select “Properties”.

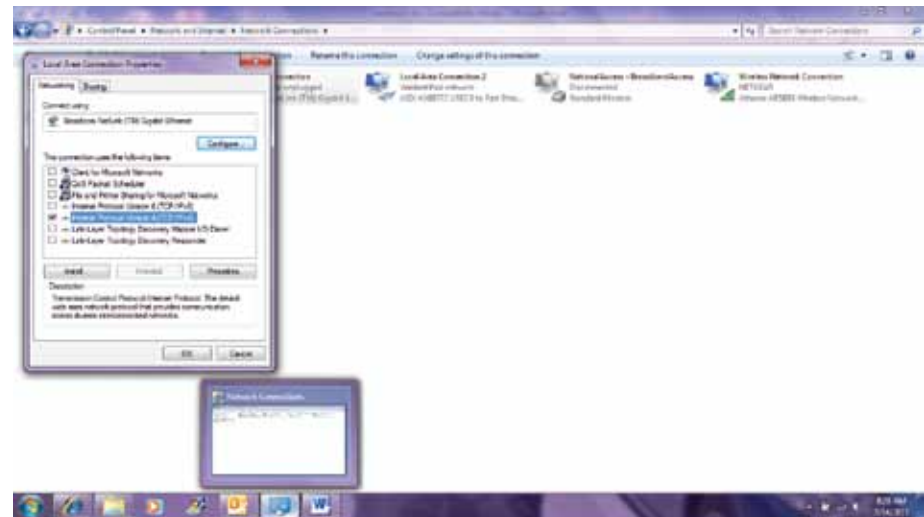

APPENDIX C: Windows 7 Set-up

- Select “Use the following IP Address” and type in (192.168.0.99).

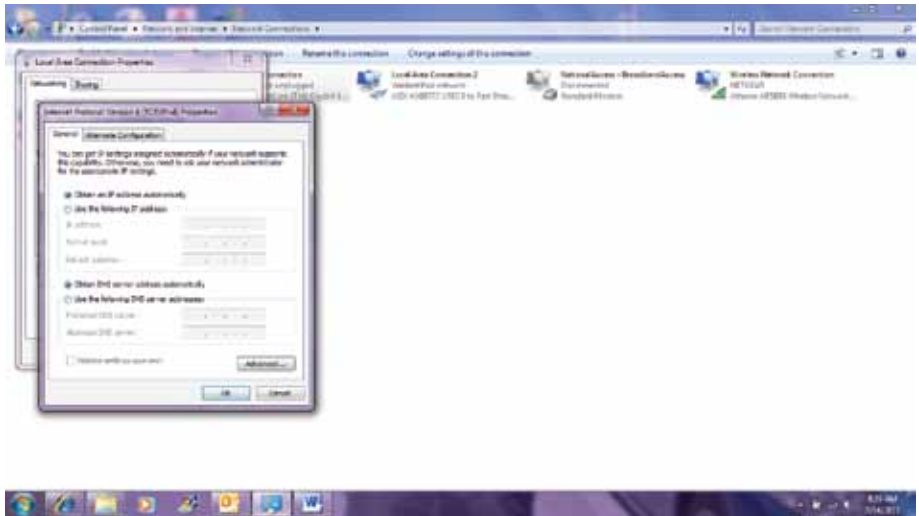

- The Subnet Mask will automatically fill in the correct address.
- Click “OK” to save setup.

