

**Section 1**

**General Description**

The CP/RX is a sophisticated radio control receiver and timing module. This single device provides 3 selectable frequencies: High Definition Radio Control™ (HDRC™), 300 MHz and 390 MHz via a three-position slide switch.

High Definition Radio Control™ is the latest breakthrough in radio frequency (RF) signal transmission. Unlike conventional RF systems, HDRC™ transmitters use sophisticated componentry to transmit a fixed frequency signal that does not distort due to outside interference. This fixed signal is then transmitted through a proprietary "electronic filter" in the CP/RX ensuring door activation occurs. For added versatility, the CP/RX includes the two most widely used conventional frequencies, 300 MHz and 390 MHz. A simple slide switch allows the CP/RX to be used interchangeably with all past MS SEDCO products and other manufacturer's products utilizing these frequencies.

In addition to the selectable frequencies, the CP/RX can be easily programmed to not only open automatic doors, but to also directly control the release of electric locking devices or sequence electric locking devices and automatic doors. The CP/RX can also be programmed so that upon receiving an initial signal, the relay remains closed until a second signal is received (ratchet relay).

**CP/RX Programmable features:**

Selectable Frequencies: via slide switch

1. High Definition Radio Control™ (HDRC™): MS SEDCO proprietary technology
2. 300 MHz: Compatible with Multicode™ products
3. 390 MHz: Compatible with MS SEDCO and GENIE™ products

Selectable Modes: via dip switches

1. Standard Receiver (factory setting)
2. Receiver with adjustable time delay (5, 10, 15 & 20 seconds)
3. Dual Receiver\*
4. Receiver with two sequenced outputs\* (lock release & door activation)
5. Receiver with ratchet relay\*\*

\* **Modes 3 & 4 require the RXM add on module that can be purchased separately or order CP/RXM for receiver with RXM installed.**

\*\* **Mode 5 requires the RXR add-on module that can be purchased separately or order CP/RXR for receiver with RXR installed.**

**Section 2**

**Basic Installation**

The physical placement of the CP/RX is typically in the door operator housing area since the power supply and operator control are already in this location, however, optimum performance is achieved with the unit located outside the door operator housing.



**ATTENTION:** The antenna wire on the receiver must be exposed outside the operator housing. Drill a small hole in the housing and expose as much of the antenna wire as possible.



**ATTENTION:** Door operator motors and controls may cause radio frequency interference (RFI) that could impair the performance of a radio control device. For best results, locate the receiver away from the motor and connect the receiver to a clean power source via a 12-24V transformer (AC or DC).

**Select Operating Mode:** Refer to the pages listed below for the detailed installation instructions for your desired operating mode.

Page 3: **Standard Receiver (factory setting—most common application)**

Page 4: Receiver with Adjustable Time Delay Output

Page 5: Dual Receiver (requires RXM Add On Module)

Page 6: Receiver with Two Sequenced Outputs (requires RXM Add On Module)

Page 7: Receiver with Ratchet Relay (Requires RXR Add-On Module)

**For additional technical assistance, please contact us toll-free at 1-800-842-2545.**



**NOTICE:** These instructions are provided for your convenience. Please verify your installation is in compliance with all local electrical codes.



**NOTICE:** This device complies with Part 15 of the FCC rules. Operation of this device is subject to the following two conditions: 1) This device may not cause harmful interference and 2) This device must accept any interference received, including interference that may cause undesired operation. Any changes or modifications not expressly approved by MS SEDCO could void the user's authority to operate this equipment.

**Section 3**

**Technical Data**

Model.....	ClearPath™ CP/RX
Input Power.....	12-24V AC or DC
Output Contact.....	Form C, Rated at 3 Amps
Relay Contact Rating.....	3A:24V AC
Temperature Rating.....	-22° F to 158° F (-30° C to 70° C)
Weight.....	<0.25 lbs.
Physical Size.....	4"L x 2"W x 1"H

Product protected by US patent 7,545,833

#### Section 4

#### Troubleshooting

When installing the ClearPath line of radio controlled products it may be necessary to troubleshoot the system. If your system is not working properly here is a basic method to troubleshoot the products.

1. **When the push plate is actuated, does the transmitter show a red LED?** [Note: You will need to view the switch/surface box assembly from the back (i.e. hold it so that the switch is facing away from you) in order to see the LED.]
  - If yes, proceed to step 2.
  - If no, check the battery and make sure the push plate is connected to the transmitter properly. Also check battery wires to ensure neither is damaged. If the transmitter continues to fail in showing the red LED, contact MS Sedco to inquire about repairing or replacing the transmitter.
  
2. **Are the 12 dip switches and frequency selection switch matched between the transmitter and receiver?**
  - If yes, proceed to step 3.
  - If no, set the dip switches or frequency selection switch to match between the transmitter and receiver.
  
3. **Does the receiver have power?** Ensure that 12- 24 V AC or DC is supplied to the Red and Black wires of the CP/RX receiver. Also ensure that the wiring harness is plugged in correctly to the receiver. Refer to the label inside the cover of the receiver to verify wire harness orientation.
  
4. **When the transmitter is triggered, does the RECEIVER show a red LED?**
  - If yes, the transmitter and receiver are working properly, but there is another issue.
  - If no, the receiver is not seeing a signal from the transmitter.
  
5. **There is a possibility that there is interference in the area.** Change the frequency settings on both the transmitter and receiver. If frequency interference is affecting the signal, changing frequencies may correct this problem. It is important to remember that regardless of the frequency settings, both the transmitter and receiver must match.
  
6. **If the receiver is not responding to a signal from the transmitter, there are a few additional things to consider:**
  - Materials such as metal, energy efficient (Low "E") glass, or other electronic devices may affect the signal. If possible, hold the transmitter near the receiver and activate it. If the receiver sees the signal there is a possibility that obstructions may

be blocking the signal where the transmitter is normally mounted, or you may be experiencing interference.

- Try activating the receiver with a different transmitter. If the receiver sees a signal from a different transmitter, there is a possibility that the original transmitter has a problem. If this occurs, contact MS Sedco about repairing or replacing the original transmitter.
  - Ensure that the receiver antenna is exposed from the header box as much as possible. If necessary, drill a small hole in the header box and pull the antenna through. Please do not cut or lengthen the antenna wire.
  - If the receiver is not responding to the signal from any transmitter, regardless of distance or frequency, it is possible the receiver may need repair. Try a different receiver if this is possible. Contact MS Sedco if receiver needs to be repaired or replaced.
7. **If receiver and transmitter are functioning correctly but door control is not activating, ensure that the output of the receiver is connected properly to the door control.** If you have questions on this, please contact MS Sedco and ask for technical support.

**MODE #1—Standard Receiver**  
(Factory Setting-Activate Door Operators)

1. SELECT FREQUENCY: Remove CP/RX cover and select the desired frequency to match the transmitters via the 3-position slide switch on the receiver circuit board (Fig. 1).
2. SELECT SECURITY CODE: Select the desired security code to match the transmitters via the 12 dip switches on the CP/RX circuit board (Fig. 1).
3. SELECT OPERATING MODE: Factory setting is Mode #1- DO NOTHING.

**Figure 1**

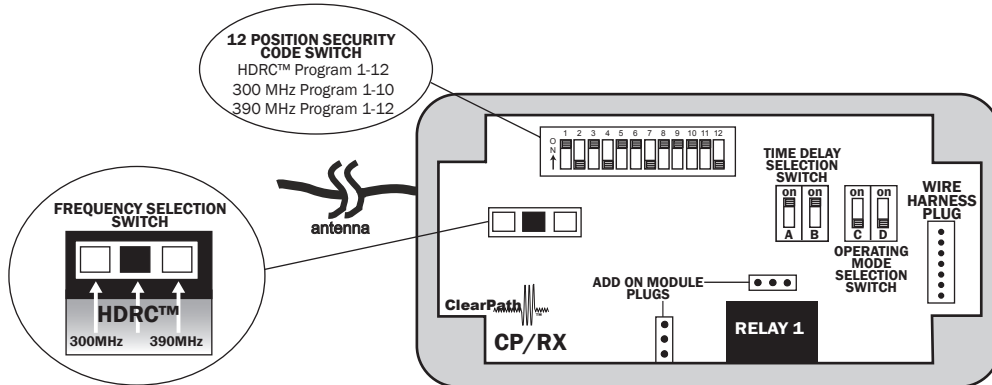

4. Mount the CP/RX in its intended location and plug in the provided wiring harness.
5. Connect device to be controlled to appropriate wires (Fig. 2).
6. Connect power to the appropriate wires (Fig. 2).
7. Install CP/RX cover with 4 screws provided.



**ATTENTION:** If CP/RX is installed inside a door operator housing, drill a small hole in the housing and pull the receiver antenna wire through it to ensure radio reception is not inhibited.

**Figure 2**

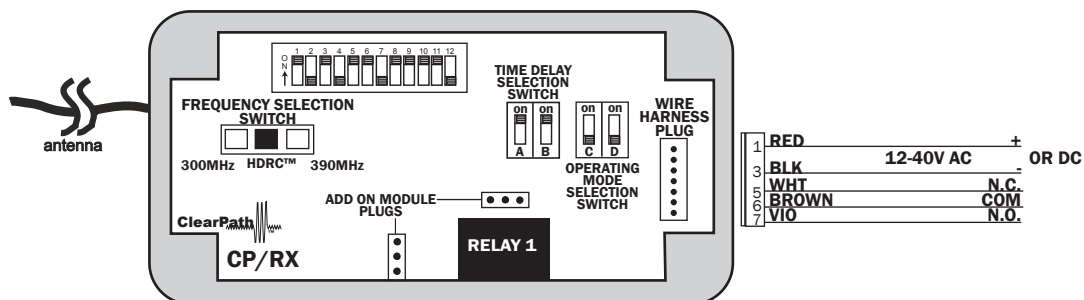

Input Voltage: 12 - 24V AC or DC

RED + (POS)

BLACK - (NEG)

\*Surge suppression circuitry is built in. Therefore it can directly drive Mag Locks or Electric Strikes without additional protection.

**MODE #2—Receiver With Adjustable Time Delay Output**  
(Releases Electric Locking Devices)

1. SELECT FREQUENCY: Remove CP/RX cover and select the desired frequency to match the transmitters via the 3-position slide switch on the receiver circuit board (Fig. 1).
2. SELECT SECURITY CODE: Select the desired security code to match the transmitters via the 12 dip switches on the CP/RX circuit board (Fig. 1).
3. SELECT OPERATING MODE: Using the Table 1 select Mode #2 via the dip switches marked C & D located on the CP/RX circuit board (Fig. 1).
4. SELECT TIME DELAY: Using Table 2 select the desired time delay via the dip switches marked A & B on the CP/RX printed circuit board (Fig. 1).

**Table 1**

Mode#	C	D	Operating Mode
1	OFF	OFF	Normal Receiver (Factory Setting)
2	ON	OFF	Receiver with Time Delayed Output

**Table 2**

A	B	Time Delay
ON	ON	5 Seconds
ON	OFF	10 Seconds
OFF	ON	15 Seconds
OFF	OFF	20 Seconds

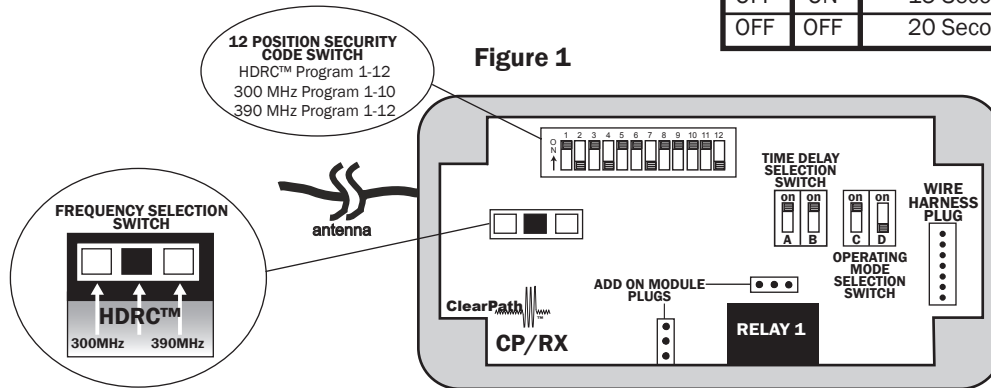

5. Mount the CP/RX in its intended location and plug in the provided wiring harness.
6. Connect device to be controlled to appropriate wires (Fig. 2).
7. Connect power to the appropriate wires (Fig. 2).
8. Activate the CP/RX to verify the system is working properly. If further time delay adjustment is required to the unit, refer back to step 4.



**ATTENTION:** Changing the operating mode or time delay settings after power is applied requires a 6 second delay for the new programming to take effect.

9. Install CP/RX cover with 4 screws provided.



**ATTENTION:** If CP/RX is installed inside a door operator housing, drill a small hole in the housing and pull the receiver antenna wire through it to ensure radio reception is not inhibited.

**Figure 2**

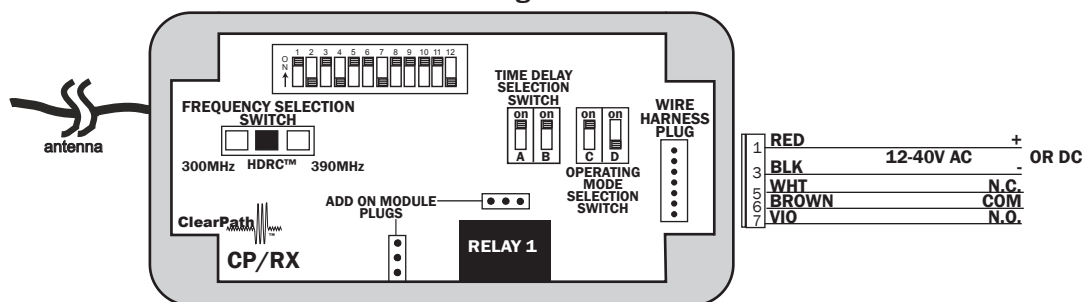

Input Voltage: 12 - 24V AC or DC, RED + (POS), BLACK - (NEG)

\*Surge suppression circuitry is built in. Therefore it can directly drive Mag Locks or Electric Strikes without additional protection.

**MODE #3—Dual Receiver**  
 (Day/Night Function)

**NOTE: This Mode requires BOTH the CP/RX and the RXM ADD ON MODULE**

1. SELECT FREQUENCY: Remove CP/RX cover and select the desired frequency to match the transmitters via the 3-position slide switch on the receiver circuit board (Fig. 1).
2. SELECT SECURITY CODE: Select the desired security code to match the transmitters via the 12 dip switches on the CP/RX circuit board (Fig. 1).
3. SELECT OPERATING MODE: Using table below select mode #3 via the dip switches marked C & D located on the CP/RX printed circuit board.

**Table 1**

Mode#	C	D	Operating Mode
1	OFF	OFF	Normal Receiver (Factory Setting)
2	ON	OFF	Receiver with Time Delayed Output
3	OFF	ON	Dual Receiver
4	ON	ON	Receiver With Sequenced Outputs
5	N/A	N/A	Receiver With Ratchet Relay

**Figure 1**

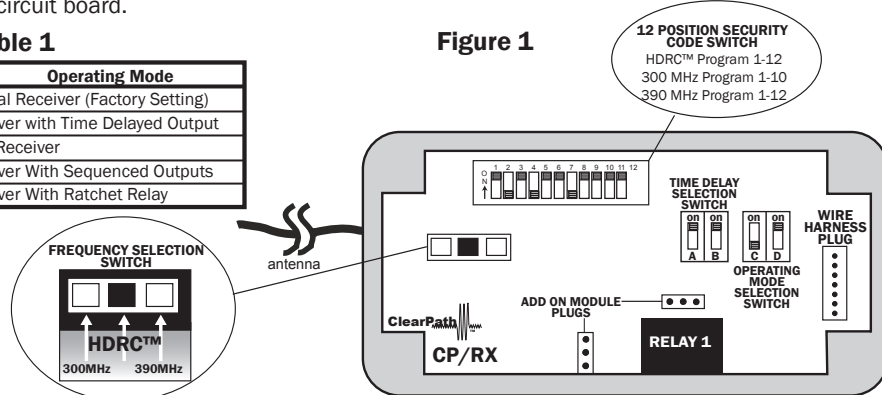

4. Set one transmitter to match the security code of the CP/RX selected in step 2. Set a second transmitter to this same code EXCEPT dip switch #2 which should be opposite to dip switch #2 on the CP/RX (Fig. 2).

**Figure 2**

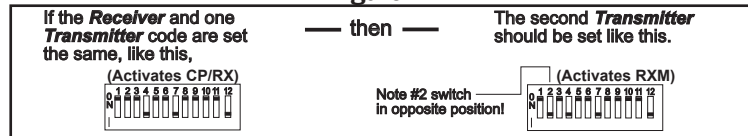

5. Plug the 3-lead wire harness supplied with the RXM (purchased separately) into its connector on the RXM circuit board and then plug the entire assembly onto the CP/RX circuit board (Fig. 3).
6. Mount the CP/RX in its intended location and plug the 5-lead wiring harness provided into its connector on the CP/RX circuit board (Fig. 3).
7. Connect each device to be controlled to the appropriate wires (Fig. 3).
8. Connect power to the appropriate wires (Fig. 3).



**ATTENTION:** Changing the operating mode or time delay settings after power is applied requires a 6 second delay for the new programming to take effect.

9. Install CP/RX cover with 4 screws provided.



**ATTENTION:** If CP/RX is installed inside a door operator housing, drill a small hole in the housing and pull the receiver antenna wire through it to ensure radio reception is not inhibited.

**Figure 3**

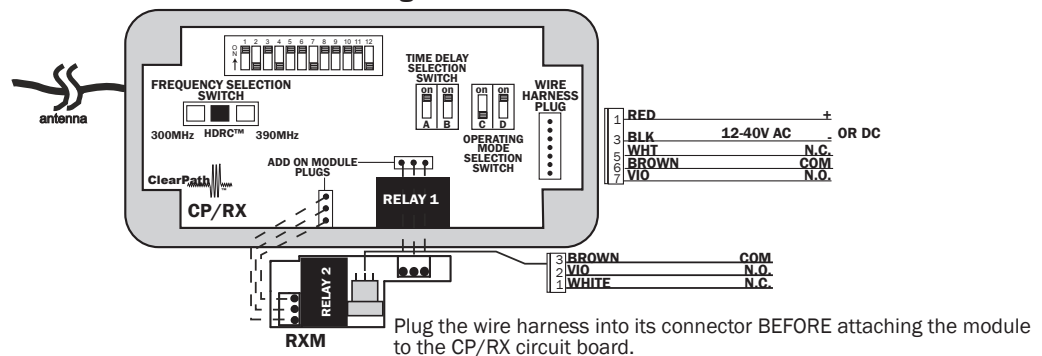

Plug the wire harness into its connector BEFORE attaching the module to the CP/RX circuit board.

**MODE #4—Receiver With Two Sequenced Outputs**  
(Sequences Electric Locks & Door Operators)

**NOTE: This Mode requires BOTH the CP/RX and the RXM ADD ON MODULE**

1. SELECT FREQUENCY: Remove CP/RX cover and select the desired frequency to match the transmitters via the 3-position slide switch on the receiver circuit board (Fig. 1).
2. SELECT SECURITY CODE: Select the desired security code to match the transmitters via the 12 dip switches on the CP/RX circuit board (Fig. 1).
3. SELECT OPERATING MODE: Using Table 1 select Mode #4 via the 2 dip switches marked C & D located on the CP/RX printed circuit board.
4. SELECT TIME DELAY: Using Table 2 select the desired output time delays via the dip switches marked A & B on the CP/RX circuit board.

**Table 1**

Mode#	C	D	Operating Mode
1	OFF	OFF	Normal Receiver (Factory Setting)
2	ON	OFF	Receiver with Time Delayed Output
3	OFF	ON	Dual Receiver
4	ON	ON	Receiver With Sequenced Outputs
5	N/A	N/A	Receiver With Ratchet Relay

**Table 2**

A	B	Time Delay
ON	ON	5 Seconds
ON	OFF	10 Seconds
OFF	ON	15 Seconds
OFF	OFF	20 Seconds

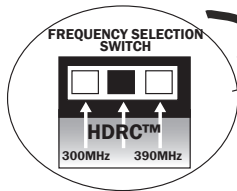

**Figure 1**

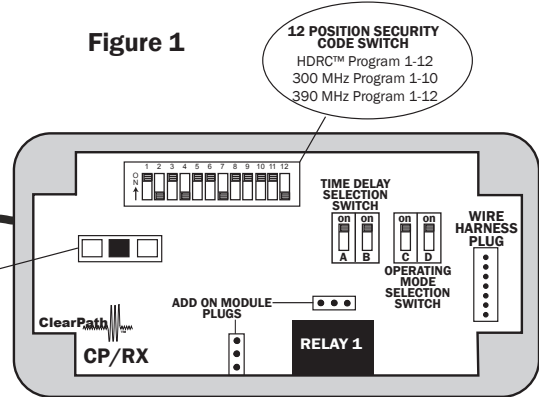

5. Plug the 3-lead wire harness supplied with the RXM (purchased separately) into its connector on the RXM circuit board and then plug the entire assembly onto the CP/RX circuit board (Fig. 2).
6. Mount the CP/RX in its intended location and plug the 5-lead wiring harness provided into its connector on the CP/RX circuit board (Fig. 2).
7. Connect each device to be controlled to the appropriate wires (Fig. 2).



**NOTE:** Relay #1 on the CP/RX circuit board activates first. Relay #2 on the RXM add on module activates second.

8. Connect power to the appropriate wires (Fig. 2).
9. Activate the CP/RX to verify the system is working properly. If further time delay adjustment is required to the unit, refer back to step 4.



**ATTENTION:** Changing the operating mode or time delay settings after power is applied requires a 6 second delay for the new programming to take effect.

10. Install CP/RX cover with 4 screws provided.



**ATTENTION:** If CP/RX is installed inside a door operator housing, drill a small hole in the housing and pull the receiver antenna wire through it to ensure radio reception is not inhibited.

**Figure 2**

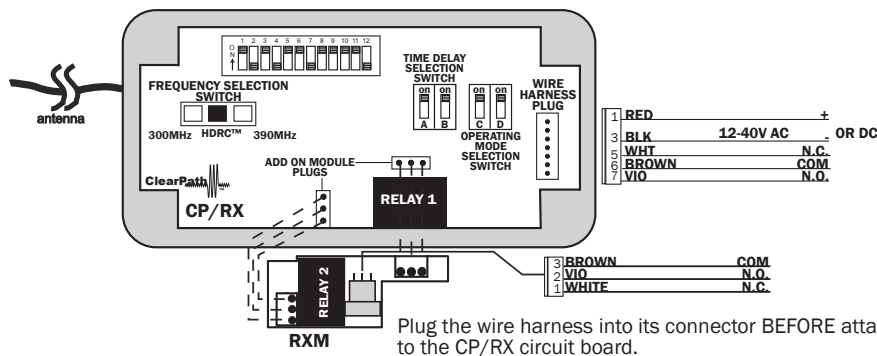

**MODE #5—Receiver With Ratchet Relay**

(Initial Signal Holds Relay Closed Until A Second Signal Is Received)

**NOTE: This Mode requires BOTH the CP/RX and the RXR ADD ON MODULE**

1. SELECT FREQUENCY: Remove CP/RX cover and select the desired frequency to match the transmitters via the 3-position slide switch on the receiver circuit board (Fig. 1).
2. SELECT SECURITY CODE: Select the desired security code to match the transmitters via the 12 dip switches on the CP/RX circuit board (Fig. 1).
3. SELECT OPERATING MODE: Plug the RXR (purchased separately) onto the main PCB (Fig. 2). The relay will automatically convert to the ratchet mode—no operating mode switch is necessary (Table 1).
4. Mount the CP/RX in its intended location and plug the 5-lead wiring harness provided into its connector on the CP/RX circuit board (Fig. 2).

**Table 1**

Mode#	C	D	Operating Mode
1	OFF	OFF	Normal Receiver (Factory Setting)
2	ON	OFF	Receiver with Time Delayed Output
3	OFF	ON	Dual Receiver
4	ON	ON	Receiver With Sequenced Outputs
5	N/A	N/A	Receiver With Ratchet Relay

**Figure 1**

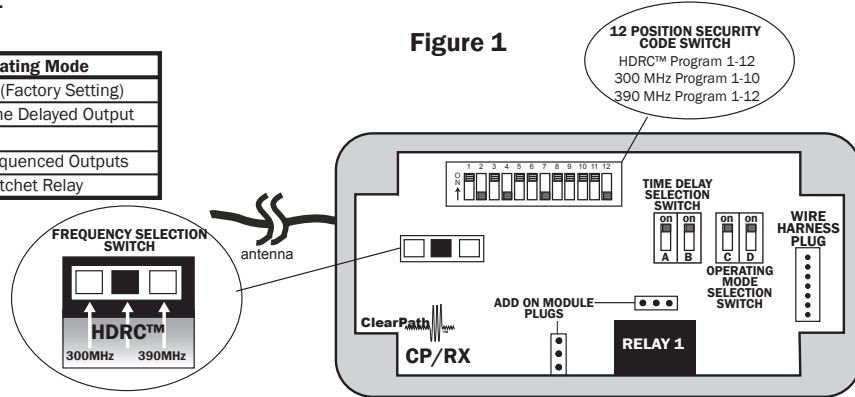

5. Connect device to be controlled to the appropriate wires (Fig. 2).
6. Connect power to the appropriate wires (Fig. 2).
7. Activate the CP/RX to verify the system is working properly.



**ATTENTION:** Changing the operating mode or time delay settings after power is applied requires a 6 second delay for the new programming to take effect.

8. Install CP/RX cover with 4 screws provided.



**ATTENTION:** If CP/RX is installed inside a door operator housing, drill a small hole in the housing and pull the receiver antenna wire through it to ensure radio reception is not inhibited.

**Figure 2**

