

RECEIVER DIAGRAM:

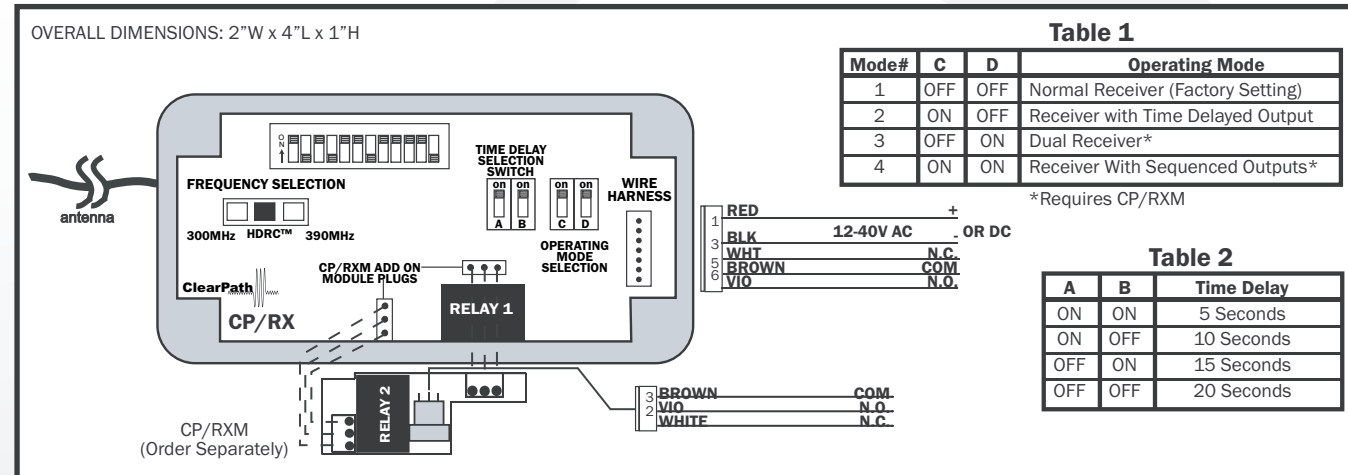

TRANSMITTER DIMENSIONAL DIAGRAMS:

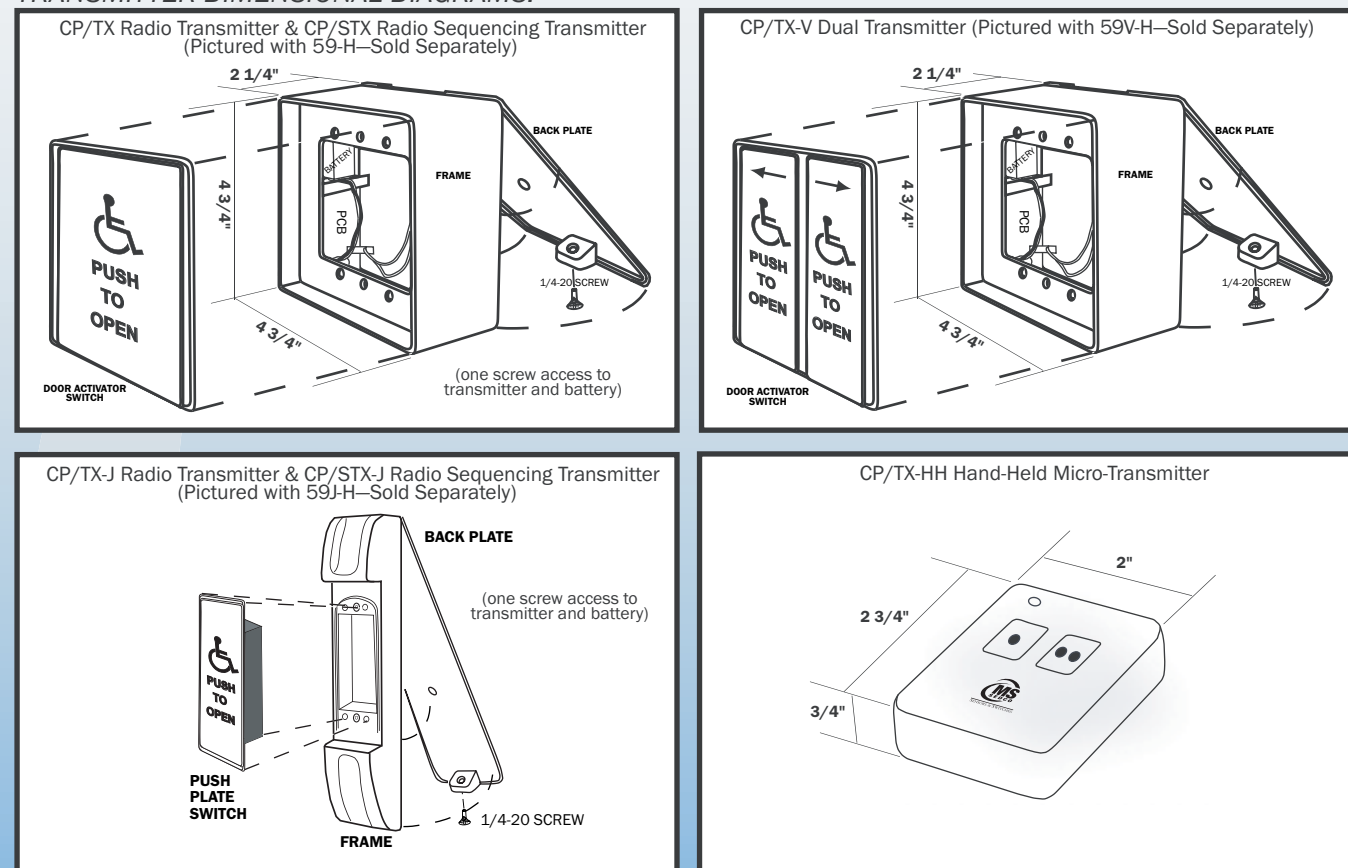

ClearPath™ Radio Control Door Activation System

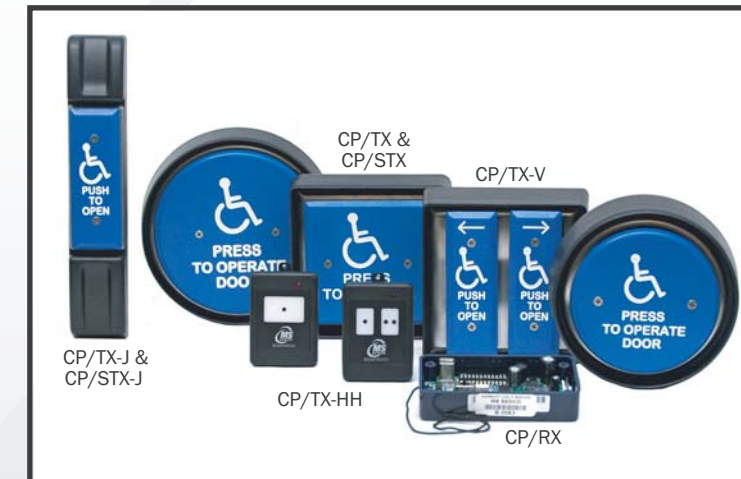

- CP/TX Radio Transmitter & CP/STX Radio Sequencing Transmitter (Pictured with 59-H)
- CP/TX-V Dual Transmitter (Pictured with 59V-H)
- CP/TX-J Radio Transmitter & CP/STX-J Radio Sequencing Transmitter (Pictured with 59J-H)
- CP/TX-HH Hand-Held Micro-Transmitters
- CP/RX Multi-Mode Receiver

ClearPath™ Radio Control Switches with HDRC™ solve problems caused by interference and stray signals—and are guaranteed to work where others won't.

ClearPath products are FCC licensed, comply with all HDRC requirements, and are compatible with previous MS SEDCO devices as well as with the products of many other manufacturers.

The ClearPath™ Radio Control Door Activation System provides the most reliable wireless activation of automatic doors available. To accomplish this, the ClearPath™ product line features several advances, the most important of which is three selectable frequencies built into each product: High Definition Radio Control™ (HDRC™), 300 MHz and 390 MHz.



High Definition Radio Control™ is the latest breakthrough in radio frequency (RF) signal transmission from MS SEDCO. Unlike conventional RF systems in use today, HDRC™ uses sophisticated componentry that transmits a fixed frequency signal that will not distort due to outside interference. This fixed signal is then transmitted through a proprietary electronic "filter" in the receiver ensuring door activation occurs. For added versatility, each ClearPath™ device also includes the two most widely used conventional frequencies, 300 MHz and 390 MHz. A simple slide of a switch allows the ClearPath™ product line to be used interchangeably with all past MS SEDCO products and other manufacturers products that operate at these frequencies.

ClearPath™ Transmitters:

- CP/TX (wall mount transmitter)
- CP/TX-J (jamb mount transmitter)
- CP/TX-HH (handheld transmitter)

All ClearPath™ transmitters share the same printed circuit board (PCB), come prewired and installed with a battery in a mounting box and feature these additional MS SEDCO exclusive advantages:

Selectable Frequencies: High Definition Radio Control™ (HDRC™), 300 MHz & 390 MHz all in one device.

SignalLock™: When a door activator switch is pressed, SignalLock™ instantaneously captures the switch signal and transmits its radio signal for the maximum allowable time under FCC rules. This guarantees that a radio signal is transmitted every time the switch is activated.

Signal Enhancing Antenna (CP/TX & CP/STX): Boosts the radiating strength of the transmitter signal to ensure long distance door activation.

Proprietary Mounting Box (CP/TX & CP/STX): Allows the switch to mount recessed within the box improving weather resistance and eliminating "snagging". Battery replacement is simple thanks to its two-piece design that requires only one screw be removed to gain access to the battery.

Extended Battery Life: Power saving circuitry design lowers battery drain 50% doubling the battery life.

ClearPath™ Vestibule Transmitters:

- CP/STX (wall mount sequencing transmitter)
- CP/STX-J (jamb mount sequencing transmitter)
- CP/TX-V (wall mount dual transmitter)

The ClearPath™ vestibule transmitters share all features found in the standard transmitters.

Additionally, the CP/STX wall mount and CP/STX-J jamb mount vestibule transmitters receive a programming upgrade that enables them to be

sequencing transmitters. They are capable of transmitting two separate signals with an adjustable time delay between them to sequence vestibule doors one after the other from either direction. Because no additional circuit boards or batteries are required, ClearPath™ is the only system to offer the sequencing option on both jamb mounted and wall mounted versions.

The CP/TX-V is a dual transmitter that mounts in the vestibule between the doors. When used with the 619 series vestibule switches the CP/TX-V allows for independent activation of two separate doors.

Technical Data: Transmitters

- Utilizes Proprietary High Definition Radio Control™ (HDRC™) For Unsurpassed Signal Transmission Clarity
- Three User Selectable Frequencies Available In Single Unit: HDRC™, 300 MHz, 390 MHz
- FCC License For All Three Frequencies
- SignalLock™ Guarantees Signal Transmission When Door Activator Switch Is Pressed
- Power Saving Circuitry Extends Battery Life
- Integrated Signal Radiating Antenna Boosts Signal Strength
- Vestibule Transmitters Sequence Two Doors With User Adjustable Time Delay Between Signals Of 3, 5 Or 10 Seconds
- Transmitter And Battery Factory Prewired And Installed In Mounting Boxes
- Switch Activated Transmitters Powered By Standard 9V Battery
- Handheld Micro-Transmitter (CP/TX-HH) Has A Compact Overall Size With Large Activation Buttons. One And Two Buttons Available. Powered By 12V Battery
- Optional Recessed 2-Gang Mounting Boxes Available

ClearPath™ Receiver: CP/RX

The ClearPath™ receiver also includes the three selectable frequencies HDRC™, 300 MHz and 390 MHz. In addition to being a selectable frequency receiver, the CP/RX is a sophisticated timer that

VESTIBULE DIAGRAM:

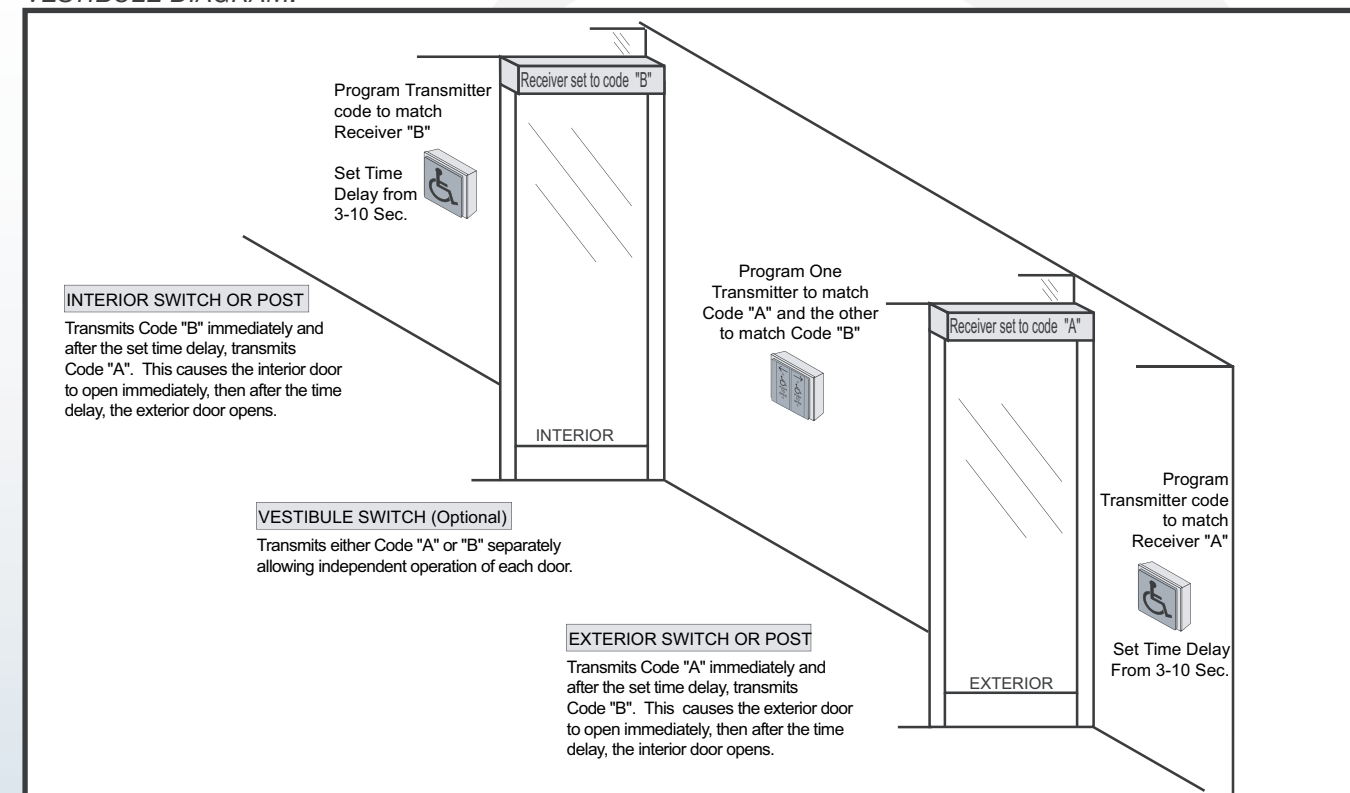

can not only be used to activate automatic doors, but can also be used to directly release electric locking devices or sequence electric locking devices on automatic doors without any additional relays or timers.

With the simple slide of a switch the CP/RX can provide each of the following functions:

1. Standard receiver (factory setting).
2. Receiver with adjustable time delay output of 5, 10, 15, 20 seconds.
3. Dual channel receiver. Two receivers that operate independently from each other in the same housing.
4. Receiver with 2 sequenced outputs. Unit wires directly to both an electric locking device and an automatic door. It then provides the necessary time delay between releasing the lock and activating the door operator.

Product protected by US patent 7,545,833

Technical Data: Receiver

- Utilizes Proprietary High Definition Radio Control™ (HDRC™) For Unsurpassed Signal Transmission Clarity
- Three User Selectable Frequencies Available In Signal Unit: HDRC™, 300 MHz, 390 MHz
- FCC License For All Three Frequencies
- 4 Programming Modes:
 - Mode 1: Standard Receiver (factory setting)
 - Mode 2: Receiver With Adjustable Time Delay
 - Mode 3*: Dual Channel Receiver
 - Mode 4*: Receiver With Sequenced Outputs
- *Both Mode 3 & 4 Require The CP/RXM. This Module Plugs Directly Onto The CP/RX Main Circuit Board And Provides A Second Output.
- N.O. And N.C. Contacts
- Pluggable Wire Harness
- Internal Surge Protection Wires Directly To Electric Locking Devices
- Output Contact: Form C, Rated At 3 Amps
- Power Requirements: 12V To 24V AC or DC
- Relay Contact Rating: 3 amp @ 24V AC
- Compact Size: 4"L x 2"W x 1"H