

#614-SS (Stainless Steel with No Legend)

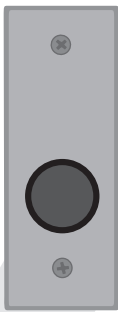

#614-NSS (Stainless Steel with No Legend)



1 1/2" Self-Sticking Mylar Face Plate Decals (Blue Background/White Legend)

**Product Name**

**614 Series**  
Extreme Switches

**Manufacturer**

MS SEDCO  
8701 Castle Park Drive  
Indianapolis, IN 46256  
Phone: (800) 842-2545  
www.mssedco.com

**Product Description**

**BASIC USE**  
The 614 Series extreme switches

are designed to provide reliable activation of any automatic door in extreme environments.

The 614 series are virtually indestructible switches. The 1" diameter red anodized aluminum button utilizes a piezo material that has no moving parts. Ideal for industrial clean rooms or other wet environments, the 614 is completely waterproof.

Two different size face plates are available. Both are formed, heavy gauge stainless steel. The 614 series switches will fit a single-gang electrical box or a 1 3/4" door frame. Surface mount boxes are also available.

**Technical Data**

- Virtually Indestructible Switch
- 1" Diameter Red Anodized Pressure Sensitive (5 lbs.) SPST Button
- Face Plate Sizes:  
Single-gang—4 1/2" x 4 1/2"  
Jamb—1 11/16" x 4 1/2"
- Waterproof—Completely Sealed
- Weatherproof (-40 ° F to 257 ° F)
- No Moving Parts—Patented Solid State Piezo Technology
- Tested To 50 Million Cycles
- Radio Control Versions Available

**DIMENSIONS**  
See Reverse

**ClearPath** 

*ClearPath™ Radio Control Switches with HDRC™ solve problems caused by interference and stray signals — and are guaranteed to work where others won't.*

**APPLICABLE STANDARDS**

American National Standards Institute (ANSI) - Building Hardware Manufacturers Association (BHMA) - ANSI/BHMA A156.10 & A156.19.

**APPROVALS**

IP68 Enclosure

**Installation**

Refer to MS SEDCO Installation Instruction Sheet.

*Custom Applications:*

The 614 Series switch can be customized in a variety of ways. Virtually any legend can be placed on the face plate as well as custom colors or finishes. Contact the factory for pricing.

**Availability & Cost**

**AVAILABILITY**  
Available internationally from manufacturer's authorized distributors; contact MS SEDCO for the location of nearest distributor.

**COST**

Cost information on MS SEDCO products is available from the manufacturer's authorized distributor.

## 614 Series Extreme Switches



SENSORS & SWITCHES

### Warranty

MS SEDCO, Inc. guarantees this product to be free from manufacturing defects for three years from date of installation. Unless MS SEDCO is notified of the date of installation, the warranty will be in effect for three years from the date of shipment from our factory. If, during the first three years, this product fails to operate and has not been tampered with or abused, the unit can be returned prepaid to the factory and be repaired free of charge. After three years, the unit will be repaired for a nominal service charge. **Limited warranty is in lieu of all other warranties, expressed or implied, including any implied warrantability of merchantability. No representative or person is authorized to assume for MS SEDCO any other liability in connection with the sale of our products. All warranties are limited to the duration of this written limited warranty. In no event shall MS SEDCO be liable for any special, incidental, consequential or other damage arising from any unclaimed breach of warranty as to its products or services.**

### Maintenance

MS SEDCO recommends that all maintenance and adjustments be performed by an AAADM Certified Technician.

### Technical Services

MS SEDCO's staff of factory trained sales and service personnel offer design assistance and technical support. Local distributors are also available to assist in selecting appropriate devices for specific uses and to provide onsite installation.

### DIMENSIONS

#### Narrow Extreme Switch

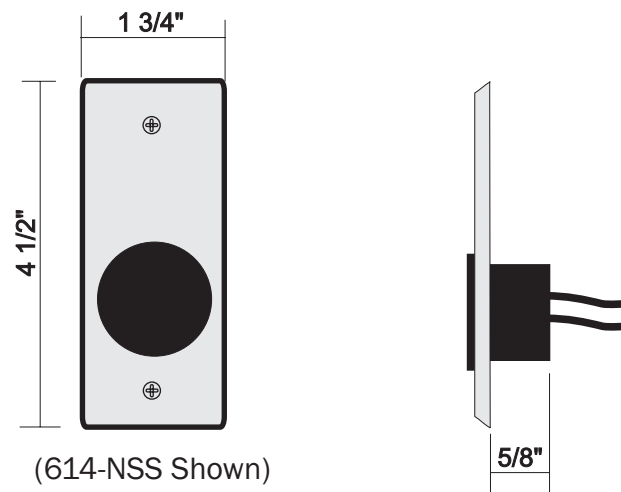

#### Single-Gang Extreme Switch

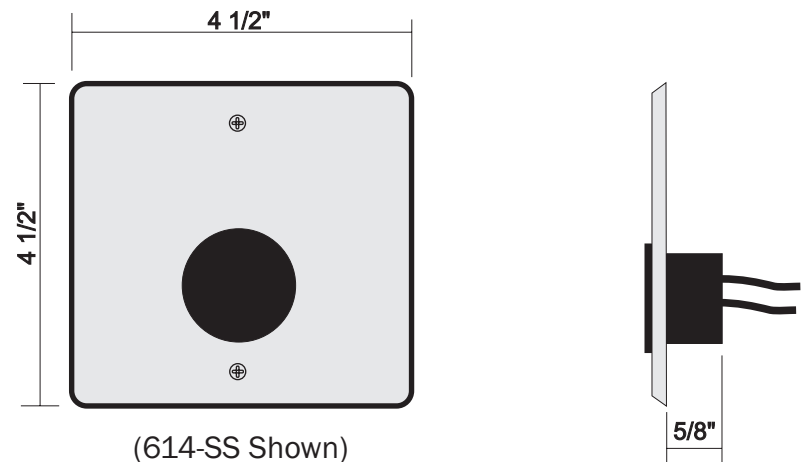

22006